



WEWOOD

PORTUGUESE JOINERY



SINCE 1964



WEWOOD

PORTUGUESE JOINERY

SINCE 1964

ABOUT

p. 4

COLLECTION

p. 17

DESIGNERS

p. 266

**MATERIALS
& COLORS**

p. 275

**CARE
& MAINTENANCE**

p. 301



OUR STORY

MANUFACTURERS SINCE 1964

Everything begins with wood and with two brothers. In 1964, in a modest joinery workshop nestled in the north of Portugal, a family story took root.

What started as a small artisanal venture between siblings grew, decade after decade, into Móveis Carlos Alfredo, a manufacturer of solid wood furniture renowned for its rigour and its roots.

For more than sixty years, that founding spirit has never wavered. The quality of our pieces is inseparable from the deep Portuguese tradition of skilled woodworking, a tradition we carry forward not as a performance of heritage, but as a living, practised commitment to excellence.



COMMITTED TO OUR COMMUNITY

We are steadfast in our belief that quality craftsmanship and social responsibility are not competing values, they are inseparable ones. Supporting the region in which we operate, preserving artisanal knowledge, and providing comfortable working conditions are not gestures: they are the pillars upon which Wewood stands.



A WORKSHOP THAT BECAME A FAMILY

Most of our craftsmen stay for life. Generations of experience accumulate within our walls, passed from master to apprentice with the same care we pour into every joint, every finish, every detail. This continuity is not incidental, it is the very foundation of our know-how.

We play an active role in the socio-economic fabric of our community. By offering stable, dignified employment close to home, we invest in the people who give our furniture its soul, and ensure that exceptional artisanal skill is never lost to time.

THE BRAND

DESIGN HOUSE GROUNDED IN HERITAGE

In 2012, after four years of careful, deliberate work, the second generation of the founding family launched Wewood - Portuguese Joinery. It was not simply a new brand. It was a declaration of intent: to build a design house proud of its heritage, grounded in the values of quality materials, durable construction, and timeless aesthetic.

Family-owned, independent, and deeply socially conscious, Wewood is committed to keeping production in Portugal, crafted in an artisanal, creative, innovative, and responsible manner. In a world of accelerating consumption, we choose to go slowly and to go well.

***LIKE OUR BUSINESS, OUR FURNITURE IS DESIGNED TO
BE PASSED DOWN FROM ONE GENERATION TO THE NEXT
WITHOUT LOSING AN OUNCE OF ITS CHARM.***





DESIGN & EXCLUSIVITY

Every piece in the Wewood collection is developed under an exclusive licence agreement with its designer, ensuring that each object is singular, intentional, and original. We do not chase trends. We seek out timeless forms, functional, aesthetically rich, and conceived to adapt to evolving lives and interiors.

Our ambition is to identify and nurture talent at every level: in the vision of a carefully selected group of international designers, and in the hands, wisdom, and experience of our craftsmen. It is in the dialogue between these two worlds, inspiration and execution, that truly extraordinary furniture is born.



THE PERFECT BALANCE

We produce for those who understand that real quality demands time, care, and an honest relationship with materials. Our pieces are crafted in small production runs. Scale, for us, is a creative constraint, not a limitation, but a guarantee of attention, grace, and integrity in every object we make.

We are driven by an unwavering passion for excellence. Not excellence as abstraction, but excellence as daily practice, in every choice of material, every join, every decision to improve rather than merely repeat.

NOBLE MATERIALS

LONG LASTING DESIGN

Wood is our medium, our language, our responsibility. Most of our furniture is crafted from solid oak and walnut, natural materials celebrated for their inherent beauty and their extraordinary capacity to age with dignity. A Wewood piece does not merely endure the passage of time. It improves with it.

The wood we select, both oak and walnut, comes exclusively from responsibly managed forests and other controlled sources. Our FSC Forest Management Certification confirms that every tree we use has been harvested in a manner that preserves biodiversity, supports local communities, and ensures the health of the forest for generations to come.

**OUR COLLECTION IS DESIGNED TO LAST AS LONG AS IT TAKES
FOR A NEW TREE TO GROW.**





INNOVATION IN SERVICE OF TRADITION

Our factory in Portugal runs on solar energy. It is equipped with state-of-the-art technology and machinery because we believe that innovation and tradition are not opposites, but partners. Our craftsmen combine the precision of advanced tools with the irreplaceable intelligence of the human hand to create furniture that no automated process could replicate.

We never cease to search for ways to improve. New materials, new techniques, new approaches to sustainability, these are ongoing conversations within our workshops, not afterthoughts. Tradition and innovation advance together here, creating new forms and new functions without ever abandoning what makes wood-working an art.



A LASTING PROMISE

We make furniture for people who value what endures. Pieces that do not go out of fashion because they were never in fashion to begin with only honest, considered, and beautiful. Pieces conceived in Portugal, shaped by skilled hands, and destined to inhabit homes and lives across the world.

At Wewood, everything we do is animated by one conviction: that excellence, sustainability, and beauty are not luxuries they are standards. And they are within reach, for those who know where to look.

COLLECTION

ACCESSORIES

CANCAN p. 20
LUNA p. 24
SIXTY'S p. 28

BEDS

PLATFORM p. 34
NORAY p. 38

BOOKSHELVES

PATH p. 46
X2 p. 54

CHAIRS

BOTERO p. 60
CARAVELA pp. 64
DEGAS p. 76
KOBE p. 80
KUNDERA p. 84
LOOP p. 88
MULTIBANQUETA p. 92
NIDO p. 96
NOOK p. 104
OPERA p. 112
ORCA p. 116
PALA p. 120
VIO pp. 124

DESKS & CONSOLES

BRIDGE p. 134
METIS p. 138
RE-FORM p. 142

SOFAS

BOWIE p. 148
DOME p. 152
SCAFFOLD p. 158

STORAGE

BRUTALIST p. 166
CAROUSEL p. 170
CONTADOR p. 174
MISTER p. 182
RADIO p. 186
SCARPA p. 190
TOUCH p. 194

TABLES

ANCHOR p. 200
AMOS p. 208
CORNER p. 216
CRIADO-MUDO p. 220
DUPLEX & TRIPLEX p. 224
HEXA p. 228
KAYA p. 232
MEMÓRIA p. 240
NURIA p. 242
RAIA p. 248
RE-FORM p. 252
SOMA p. 2556
VASCO p. 260

ACCESSORIES

CANCAN COAT STAND

BY STUDIO GUD





CANCAN COAT STAND

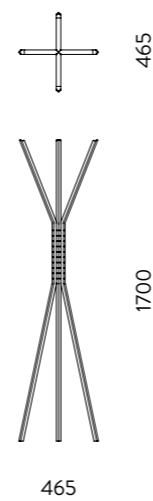

by STUDIO GUD, 2013

Cancan is a piece where shape meets function, with special attention to details such as the cut on the edge of each pole to safely hang coats. Functional but at the same time sculptural that will embellish any space.

DIMENSIONS
W 465 H 1700 D 465

MATERIALS
STRUCTURE SOLID WOOD
ROPE LEATHER
DETAIL BRASS

WOOD
OAK NATURA
OAK WHITE OIL
OAK SMOKED OPEN PORE
OAK GOLDEN BROWN
WALNUT NATURA
WALNUT UV PROTECT

REFERENCES
WCBGU001C OAK
WCBGU001N WALNUT

PRODUCT SHEET DOWNLOAD
WEWOOD.EU



LUNA MIRRORS

BY ELEONORA FEDI





LUNA MIRRORS

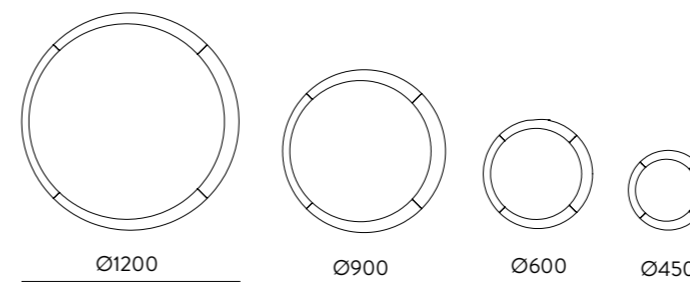

by ELEONORA FEDI, 2017

Luna is a series of mirrors inspired by the beautiful and fascinating shape of the full and crescent moon. It can be used as a single mirror or combined to create different décor sets.

DIMENSIONS

Ø 1200
Ø 900
Ø 600
Ø 450

MATERIALS

FRAME SOLID WOOD
MIRROR BRONZE | NORMAL

WOOD

OAK NATURA
OAK WHITE OIL
OAK SMOKED OPEN PORE
OAK GOLDEN BROWN
WALNUT NATURA
WALNUT UV PROTECT

REFERENCES

WEDEF001C Ø 1200 OAK
WEDEF001N Ø 1200 WALNUT
WEDEF004C Ø 900 OAK
WEDEF004N Ø 900 WALNUT
WEDEF002C Ø 600 OAK
WEDEF002N Ø 600 WALNUT
WEDEF003C Ø 450 OAK
WEDEF003N Ø 450 WALNUT

PRODUCT SHEET DOWNLOAD
WEWOOD.EU





SIXTY'S MIRRORS

BY WEWOOD





SIXTY'S MIRRORS

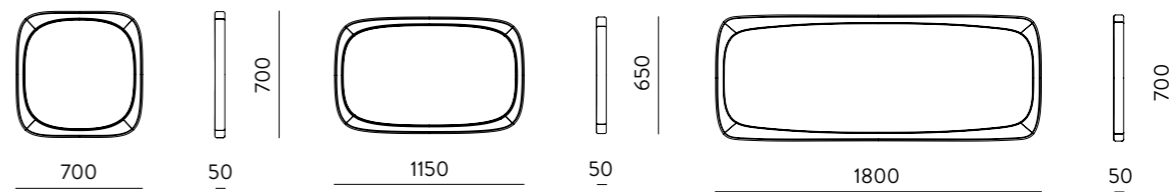

by WEWOOD, 2018

Sixty's is a collection of mirrors of different dimensions, with a solid wood frame designed to contrast. Inspired by the unique style of the 1960s. It can be placed horizontally or vertically.

DIMENSIONS
W 700 H 700 D 50
W 650 H 1150 D 50
W 700 H 1800 D 50

MATERIALS
FRAME SOLID WOOD
MIRROR BRONZE | NORMAL

WOOD
OAK NATURA
OAK WHITE OIL
OAK SMOKED OPEN PORE
OAK GOLDEN BROWN
WALNUT NATURA
WALNUT UV PROTECT

REFERENCES
WEDWW001C 700 OAK
WEDWW001N 700 WALNUT
WEDWW002C 1150 OAK
WEDWW002N 1150 WALNUT
WEDWW003C 1800 OAK
WEDWW003N 1800 WALNUT

PRODUCT SHEET DOWNLOAD
WEWOOD.EU



B E D S

PLATFORM BED

BY CHRISTIAN HAAS





PLATFORM BED

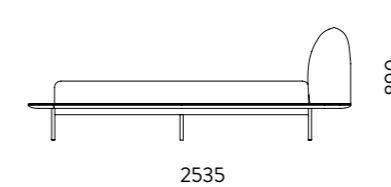
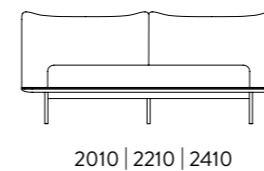

by CHRISTIAN HAAS, 2024

Platform is a sophisticated bed that effortlessly blends elegance with a touch of allure, destined to be the focal point of any bedroom.

DIMENSIONS
 W 2010 H 890 D 2535
 W 2210 H 890 D 2535
 W 2410 H 890 D 2535

MATERIALS
STRUCTURE SOLID WOOD
LEGS METAL
UPHOLSTERY FABRICS | LEATHERS

WOOD
OAK NATURA
OAK WHITE OIL
OAK SMOKED OPEN PORE
OAK GOLDEN BROWN
WALNUT NATURA
WALNUT UV PROTECT

REFERENCES
WCMCH001C OAK 1600
WCMCH001N WALNUT 1600
WCMCH002C OAK 1800
WCMCH002N WALNUT 1800
WCMCH003C OAK 2000
WCMCH003N WALNUT 2000

PRODUCT SHEET DOWNLOAD
 WEWOOD.EU





NORAY BED

BY ERNO DIERCKX





NORAY BED

NEW

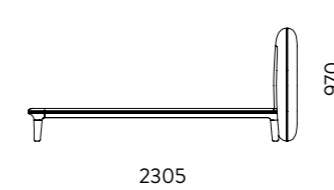
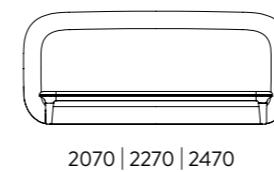

by ERNO DIERCKX, 2026

Noray is a contemporary sculptural bed, composed of soft, rounded volumes that radiate comfort and coziness. It features a large rounded edge and beautifully organic leg, paired with a fabric headboard available in a wide range of options.

DIMENSIONS
 W 2070 H 970 D 2305
 W 2270 H 970 D 2305
 W 2470 H 970 D 2305

MATERIALS
STRUCTURE SOLID WOOD
UPHOLSTERY FABRICS | LEATHERS

WOOD
OAK NATURA
OAK WHITE OIL
OAK SMOKED OPEN PORE
OAK GOLDEN BROWN
WALNUT NATURA
WALNUT UV PROTECT

REFERENCES
WCMDX001C OAK 1600
WCMDX001N WALNUT 1600
WCMDX002C OAK 1800
WCMDX002N WALNUT 1800
WCMDX003C OAK 2000
WCMDX003N WALNUT 2000

PRODUCT SHEET DOWNLOAD
 WEWOOD.EU



BOOKSHELVES



PATH SHELVING SYSTEM

BY DAN YEFFET

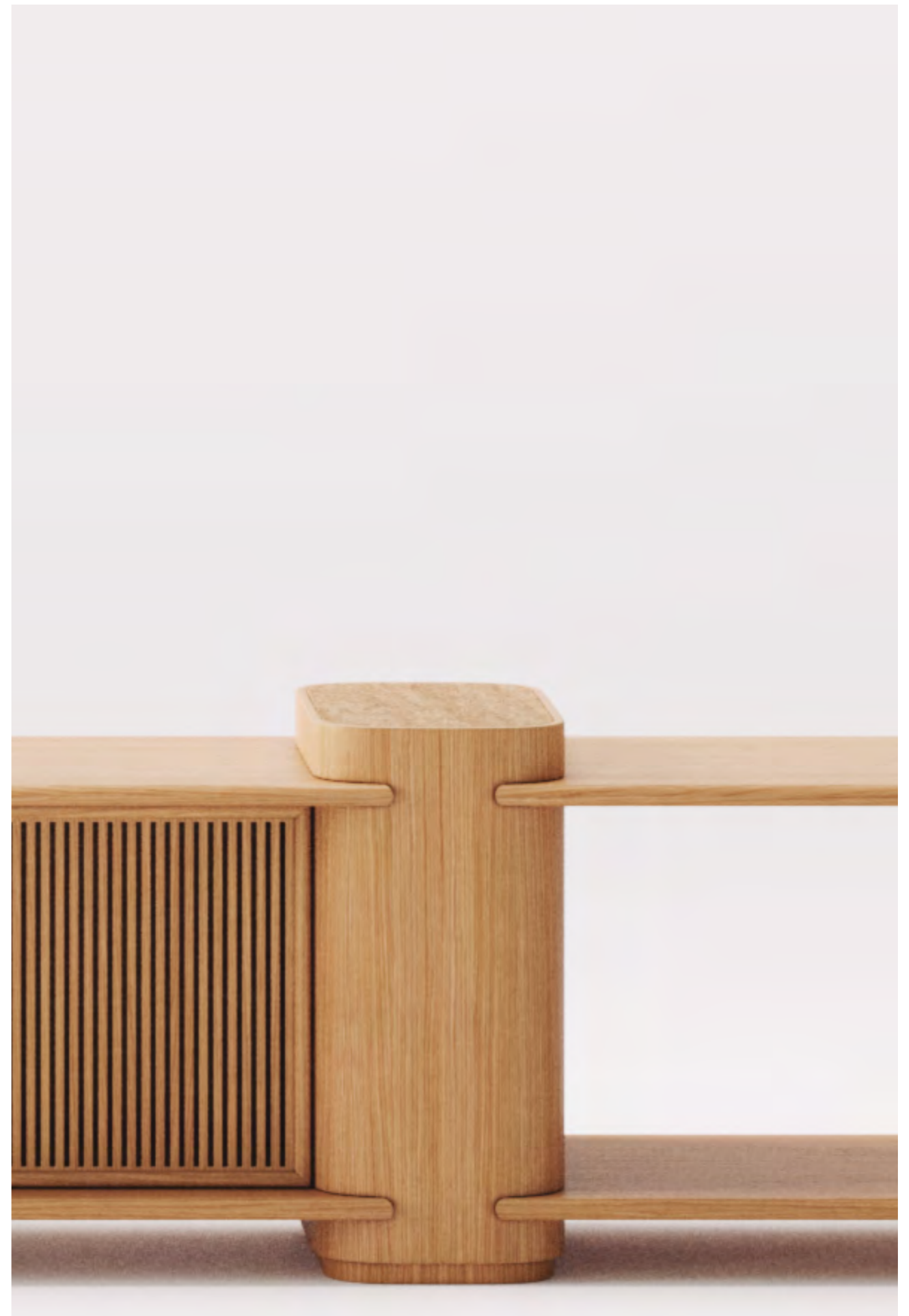



PATH SHELVING SYSTEM



by DAN YEFFET , 2026

Path is a modular wooden shelving system designed for versatility, combining shelves and storage boxes to maximize space while maintaining an open, architectural aesthetic. Constructed as a network of interconnected "islands," Path creates a dynamic, customizable layout that adapts to any interior design style.

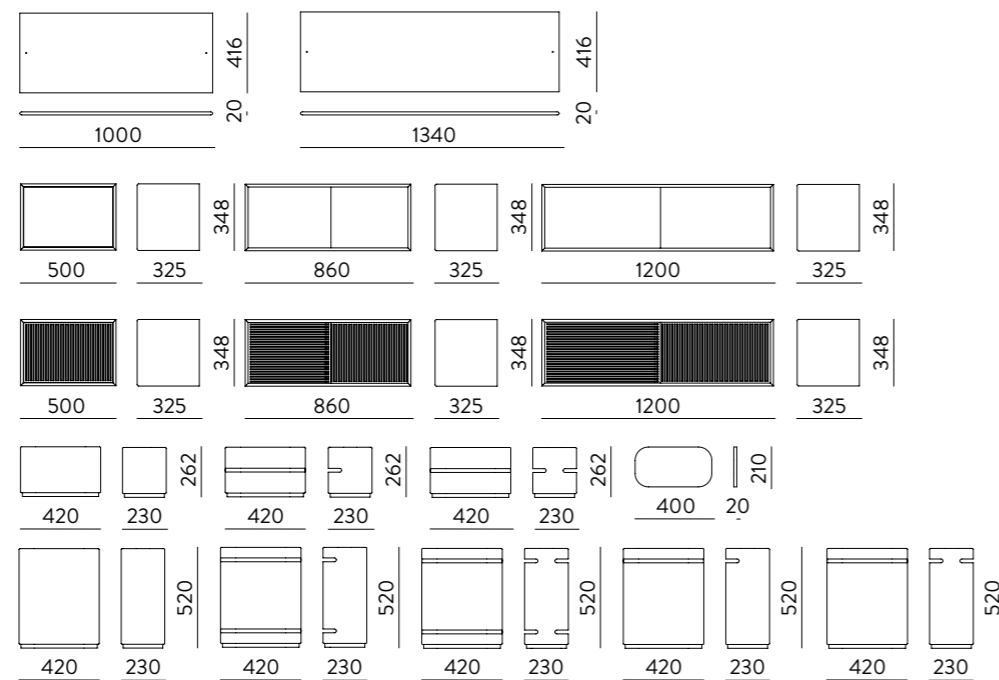

MATERIALS

SHELVES OAK | WANUT VENEER
CABINETS OAK | WANUT VENEER
MODULES OAK | WANUT VENEER
DETAILS TRAVERTINE

WOOD

OAK NATURA
OAK WHITE OIL
OAK SMOKED OPEN PORE
OAK GOLDEN BROWN
WALNUT NATURA
WALNUT UV PROTECT

REFERENCES

SHELVES

WETDY001C SMALL OAK
WETDY001N SMALL WALNUT
WETDY002C LARGE OAK
WETDY002N LARGE WALNUT

CABINETS

WETDY003C SMALL OAK
WETDY003N SMALL WALNUT
WETDY004C SMALL SLATED OAK
WETDY004N SMALL SLATED WALNUT
WETDY005C MEDIUM OAK
WETDY005N MEDIUM WALNUT
WETDY006C MEDIUM SLATED OAK
WETDY006N MEDIUM SLATED WALNUT
WETDY007C LARGE OAK
WETDY007N LARGE WALNUT
WETDY008C LARGE SLATED OAK
WETDY008N LARGE SLATED WALNUT

MODULES

WETDY009C SMALL OAK (WITHOUT SLITS)
WETDY009N SMALL WALNUT (WITHOUT SLITS)
WETDY010C SMALL OAK (ONE SIDE SLITS)
WETDY010N SMALL WALNUT (ONE SIDE SLITS)
WETDY011C SMALL OAK (TWO SIDE SLITS)
WETDY011N SMALL WALNUT (TWO SIDE SLITS)
WETDY012C TALL OAK (WITHOUT SLITS)
WETDY012N TALL WALNUT (WITHOUT SLITS)
WETDY013C TALL OAK (ONE SIDE SLITS)
WETDY013N TALL WALNUT (ONE SIDE SLITS)
WETDY014C TALL OAK (TWO SIDE SLITS)
WETDY014N TALL WALNUT (TWO SIDE SLITS)
WETDY015C TALL OAK (ONE SIDE UPPER SLITS)
WETDY015N TALL WALNUT (ONE SIDE UPPER SLITS)
WETDY016C TALL OAK (TWO SIDE UPPER SLITS)
WETDY016N TALL WALNUT (TWO SIDE UPPER SLITS)
WETDY017T TOP COVER TRAVERTINE

DIMENSIONS

SHELVES
W 1000 H 20 D 416
W 1340 H 20 D 416
CABINETS
W 500 H 348 D 325
W 860 H 348 D 325
W 1200 H 348 D 325
MODULES
W 230 H 262 D 420
W 230 H 520 D 420
TOP COVER
W 210 H 20 D 400

PRODUCT SHEET DOWNLOAD
 WEWOOD.EU





X2 BOOKSHELF

BY LAURINDO MARTA



X2 BOOKSHELF



X2 BOOKSHELF

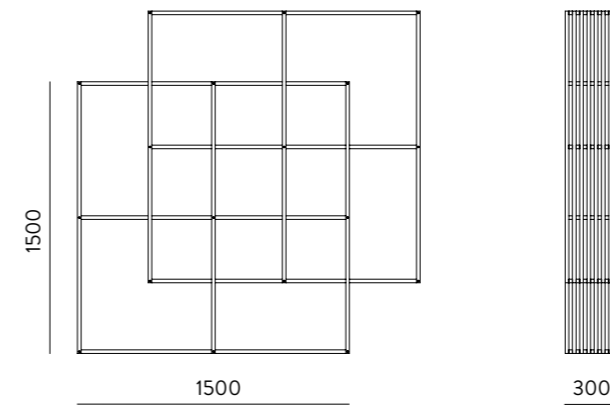

by LAURINDO MARTA, 2015

X2 is a bookshelf in solid wood fully customizable. Made from two blocks with the same size, each block is composed by 48 wooden slats that work through the brass screws that allow the movement of the blocks, ensuring the structural stability.

DIMENSIONS
W 1500 H 2220 D 300

MATERIALS
FRAME SOLID WOOD
MIRROR BRONZE | NORMAL

WOOD
OAK NATURA
OAK WHITE OIL
OAK SMOKED OPEN PORE
OAK GOLDEN BROWN
WALNUT NATURA
WALNUT UV PROTECT

REFERENCES
WETLM001C OAK
WETLM001N WALNUT

PRODUCT SHEET DOWNLOAD
WEWOOD.EU



CHAIRS
&
LOUNGE
CHAIRS



BOTERO LOUNGE CHAIR

BY FABRICIO RONCA



BOTERO LOUNGE CHAIR

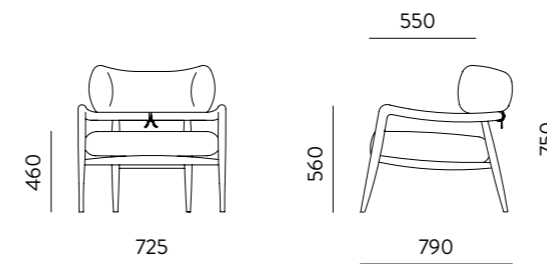

by FABRICIO RONCA, 2024

Botero is a lounge chair that combines coziness, lightness, and a striking design, built with a solid wood frame and upholstered in premium natural leather. A refined piece with a strong connection to craftsmanship.

DIMENSIONS
W 725 H 750 D 790

MATERIALS
STRUCTURE SOLID WOOD
SEAT | BACK FABRICS | LEATHERS

WOOD
OAK NATURA
OAK WHITE OIL
OAK SMOKED OPEN PORE
OAK GOLDEN BROWN
WALNUT NATURA
WALNUT UV PROTECT

REFERENCES
WCDSR002C OAK
WCDSR002N WALNUT
WCDSR002CP OAK/LEATHER
WCDSR002NP WALNUT/LEATHER

PRODUCT SHEET DOWNLOAD
WEWOOD.EU





CARAVELA BAR STOOL

BY GONÇALO CAMPOS



CARAVELA BAR STOOL

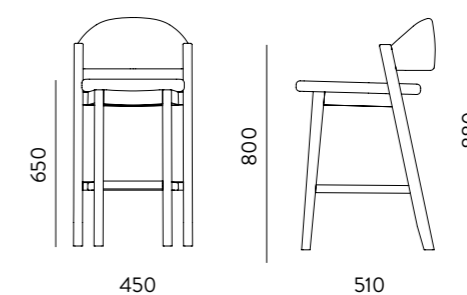
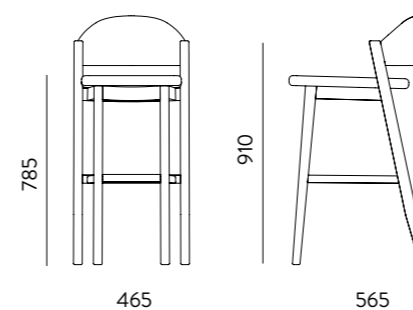

by GONÇALO CAMPOS, 2017

Caravela bar stool is the second piece from the Caravela family of chairs. Created for those who need a higher version of the chair to complete the ambience of any residential or commercial space. It also works when combined with different types of chairs.

DIMENSIONS
W 465 H 990 D 565
W 450 H 880 D 510

MATERIALS
STRUCTURE SOLID WOOD
SEAT | BACK FABRICS | LEATHERS

WOOD
OAK NATURA
OAK WHITE OIL
OAK SMOKED OPEN PORE
OAK GOLDEN BROWN
WALNUT NATURA
WALNUT UV PROTECT

REFERENCES
WCDGC002C OAK
WCDGC002N WALNUT
WCDGC007C OAK
WCDGC007N WALNUT

PRODUCT SHEET DOWNLOAD
WEWOOD.EU





CARAVELA CHAIR

BY GONÇALO CAMPOS



CARAVELA CHAIR

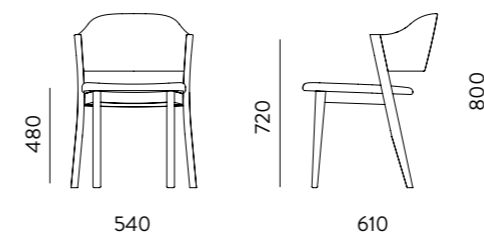

by GONÇALO CAMPOS, 2017

Caravela chair is part of a family of chairs, custom designed to furnish homes and hospitality spaces with style and elegance. Inspired by the traditional Portuguese Caravela boat, this chair is a tribute to some of the bravest in Portuguese History.

DIMENSIONS
W 540 H 800 D 610

MATERIALS
STRUCTURE SOLID WOOD
SEAT | BACK FABRICS | LEATHERS

WOOD
OAK NATURA
OAK WHITE OIL
OAK SMOKED OPEN PORE
OAK GOLDEN BROWN
WALNUT NATURA
WALNUT UV PROTECT

REFERENCES
WCDGC001C OAK
WCDGC001N WALNUT

PRODUCT SHEET DOWNLOAD
WEWOOD.EU





CARAVELA LOUNGE CHAIR

BY GONÇALO CAMPOS



CARAVELA LOUNGE CHAIR

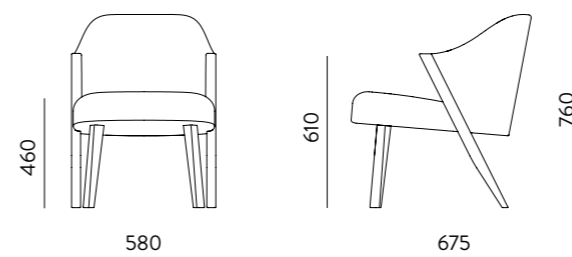

by GONÇALO CAMPOS, 2017

Caravela is a comfortable lounge chair crafted with traditional techniques of joinery. It is part of a family of chairs inspired by a highly manoeuvrable sailing ship developed in the 15th century by the Portuguese sailors and explorers.

DIMENSIONS
W 580 H 760 D 675

MATERIALS
STRUCTURE SOLID WOOD
SEAT | BACK FABRICS | LEATHERS

WOOD
OAK NATURA
OAK WHITE OIL
OAK SMOKED OPEN PORE
OAK GOLDEN BROWN
WALNUT NATURA
WALNUT UV PROTECT

REFERENCES
WCDGC003C OAK
WCDGC003N WALNUT

PRODUCT SHEET DOWNLOAD
WEWOOD.EU





DEGAS CHAIR

BY FABRICIO RONCA





DEGAS CHAIR

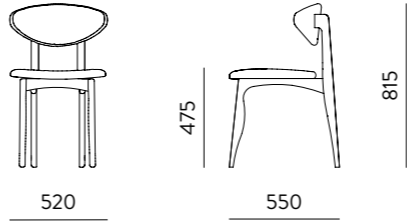

by FABRICIO RONCA, 2025

Degas is a chair crafted from solid wood, the chair features intricate detailing on its legs and backrest, complemented by a selection of premium fabrics and leather upholstery.

DIMENSIONS
W 520 H 815 D 550

MATERIALS
STRUCTURE SOLID WOOD
SEAT | BACK FABRICS | LEATHERS

WOOD
OAK NATURA
OAK WHITE OIL
OAK SMOKED OPEN PORE
OAK GOLDEN BROWN
WALNUT NATURA
WALNUT UV PROTECT

REFERENCES
WCDSR001C OAK
WCDSR001N WALNUT

PRODUCT SHEET DOWNLOAD
WEWOOD.EU





KOBE CHAIR

BY DANIEL SOUSA





KOBE CHAIR

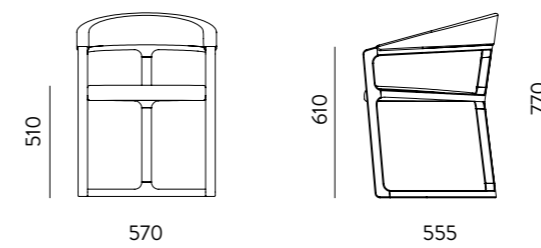

by DANIEL SOUSA, 2020

Kobe is a simple, yet interconnected chair with a solid wood frame, that is not only elegant and comfortable but also stable and robust, ideal both for domestic and contract use. Based on the Japanese aesthetic concept of Bi (totality in details). The chair got its name from the Japanese city of Kobe.

DIMENSIONS
W 570 H 770 D 555

MATERIALS
STRUCTURE SOLID WOOD
SEAT | BACK FABRICS | LEATHERS

WOOD
OAK NATURA
OAK WHITE OIL
OAK SMOKED OPEN PORE
OAK GOLDEN BROWN
WALNUT NATURA
WALNUT UV PROTECT

REFERENCES
WCDDS001C OAK
WCDDS001N WALNUT

PRODUCT SHEET DOWNLOAD
WEWOOD.EU



KUNDERA CHAIR

BY STUDIO GUD





KUNDERA CHAIR

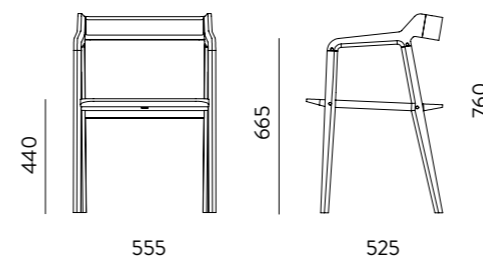

by **STUDIO GUD**, 2012

Kundera is an all-wood chair that explores the dialectic between weight and lightness. On one hand, the elegance of the design elevates it, and on the other, the weight and strength of solid wood make it closer to the earth.

DIMENSIONS
W 555 H 760 D 525

MATERIALS
STRUCTURE SOLID WOOD
SEAT FABRICS | LEATHERS

WOOD
OAK NATURA
OAK WHITE OIL
OAK SMOKED OPEN PORE
OAK GOLDEN BROWN
WALNUT NATURA
WALNUT UV PROTECT

REFERENCES
WCDGU002C OAK
WCDGU002N WALNUT
WCDGU004C OAK/FABRICS | LEATHER
WCDGU004N WALNUT/FABRICS | LEATHER

PRODUCT SHEET DOWNLOAD
WEWOOD.EU



LOOP LOUNGECHAIR

BY DAVID GIRELLI





LOOP LOUNGE CHAIR

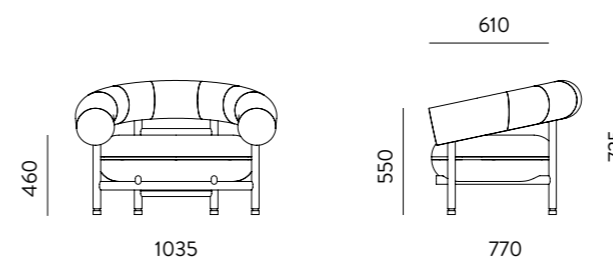

by DAVID GIRELLI, 2021

Loop is a lounge chair influenced by mid-century furniture coupled with a nordic inspired frame and solid wood legs relying upon traditional joinery techniques. The contrast between wood and upholstery is both playful and elegant.

DIMENSIONS
W 1035 H 735 D 770

MATERIALS
STRUCTURE SOLID WOOD
SEAT | BACK FABRICS | LEATHERS

WOOD
OAK NATURA
OAK WHITE OIL
OAK SMOKED OPEN PORE
OAK GOLDEN BROWN

REFERENCES
WCDDG001C OAK

PRODUCT SHEET DOWNLOAD
WEWOOD.EU





MULTIBANQUETA STOOL

BY SURICATA DESIGN STUDIO





MULTIBANQUETA STOOL

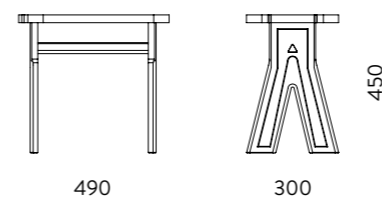

by SURICATA DESIGN STUDIO, 2012

Multibanqueta is a stool developed to offer the possibility of becoming an endless bench, inviting to gather a group of people. A multipurpose piece that can also be used as a side or coffee table.

DIMENSIONS
W 490 H 450 D 300

MATERIALS
STRUCTURE SOLID WOOD

WOOD
OAK NATURA
OAK WHITE OIL
OAK SMOKED OPEN PORE
OAK GOLDEN BROWN
WALNUT NATURA
WALNUT UV PROTECT

REFERENCES
WBCSD102C OAK
WBCSD102N WALNUT

PRODUCT SHEET DOWNLOAD
WEWOOD.EU



NIDO ARMCHAIR

BY CHRISTIAN HAAS





NIDO ARMCHAIR

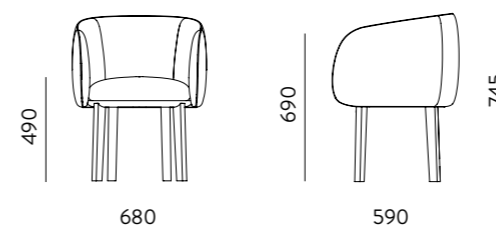

by CHRISTIAN HAAS, 2023

Nido is an armchair designed to blend seamlessly into a wide range of interiors. It is available in a variety of fabrics and leathers. The design is suitable for a private house, a hotel or an office lounge because of its versatility.

DIMENSIONS
W 680 H 745 D 590

MATERIALS
STRUCTURE SOLID WOOD
SEAT FABRICS | LEATHERS

WOOD
OAK NATURA
OAK WHITE OIL
OAK SMOKED OPEN PORE
OAK GOLDEN BROWN
WALNUT NATURA
WALNUT UV PROTECT

REFERENCES
WCDCH001C OAK
WCDCH001N WALNUT

PRODUCT SHEET DOWNLOAD
WEWOOD.EU



NIDO LOUGE CHAIR

BY CHRISTIAN HAAS





NIDO LOUNGE CHAIR

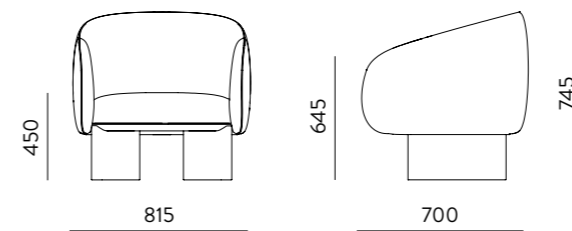

by CHRISTIAN HAAS, 2023

Nido is a compact lounge chair with a subtle sculptural presence. Its soft curves and silhouette evoke a nest-like feeling. Its welcoming upholstery is supported by a solid wood frame. Suitable for residential or commercial spaces.

REFERENCES

WCDCH002C OAK
WCDCH002N WALNUT

MATERIALS

STRUCTURE SOLID WOOD
SEAT | BACK FABRICS | LEATHERS

WOOD

OAK NATURA
OAK WHITE OIL
OAK SMOKED OPEN PORE
OAK GOLDEN BROWN
WALNUT NATURA
WALNUT UV PROTECT

DIMENSIONS
W **815** H **745** D **700**

PRODUCT SHEET DOWNLOAD
WEWOOD.EU



NOOK CHAIR

BY RAFAEL OLIVA





NOOK CHAIR

NEW

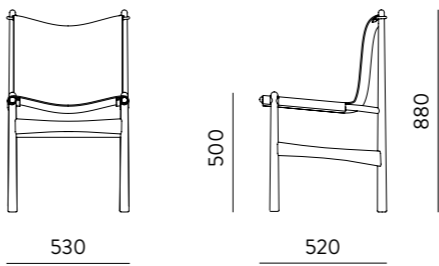

by **RAFAEL OLIVA**, 2026

Nook is a robust, durable and comfortable chair with a wooden base and a natural leather seat. Nook adapts to the user's body, providing a unique experience of interaction with the object that ages gracefully and elegantly.

DIMENSIONS
W 530 H 880 D 520

MATERIALS
STRUCTURE SOLID WOOD
DETAIL BRASS
UPHOLSTERY LEATHERS

WOOD
OAK NATURA,
OAK WHITE OIL
OAK SMOKED OPEN PORE
OAK GOLDEN BROWN
WALNUT NATURA
WALNUT UV PROTECT

REFERENCES
WCDRO001C OAK
WCDRO001N WALNUT

PRODUCT SHEET DOWNLOAD
WEWOOD.EU



NOOK LOUNGE CHAIR

BY RAFAEL OLIVA





NOOK LOUNGE CHAIR

NEW

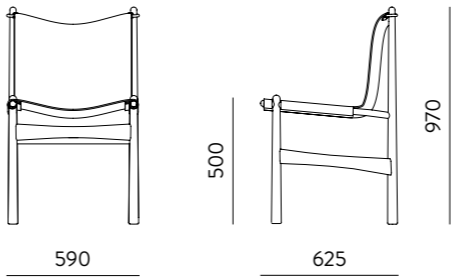

by **RAFAEL OLIVA** , 2026

Nook lounge chair is the lounge version of Nook chair. Robust, durable and comfortable chair with a wooden base and a natural leather seat. Nook adapts to the user's body, providing a unique experience of interaction with the object that ages gracefully and elegantly.

DIMENSIONS
W **590** H **970** D **625**

MATERIALS
STRUCTURE SOLID WOOD
DETAIL BRASS
UPHOLSTERY LEATHERS

WOOD
OAK NATURA
OAK WHITE OIL
OAK SMOKED OPEN PORE
OAK GOLDEN BROWN
WALNUT NATURA
WALNUT UV PROTECT

REFERENCES
WCDRO002C OAK
WCDRO002N WALNUT

PRODUCT SHEET DOWNLOAD
WEWOOD.EU



OPERA CHAISE LONGUE

BY FABRICIO RONCA





OPERA CHAISE LONGUE

NEW

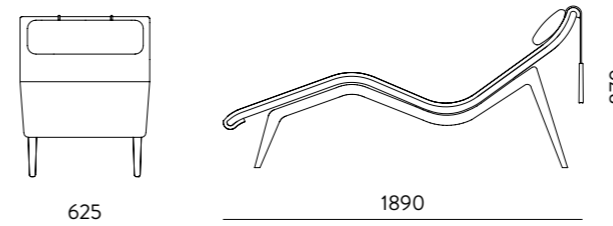

by **FABRICIO RONCA**, 2026

Opera is a classic, timeless, sophisticated piece that invites to relax. The perfect ergonomics of its curves, like music, the noble materials such as leather, wood, and the counterweight of the backrest cushion all refer to elements of the theater.

DIMENSIONS
W **625** H **870** D **1890**

REFERENCES
WCDSR04N CHAISE LONGUE WALNUT

MATERIALS
STRUCTURE SOLID WOOD
UPHOLSTERY FABRICS | LEATHERS

WOOD
WALNUT NATURA
WALNUT UV PROTECT

PRODUCT SHEET DOWNLOAD
WEWOOD.EU





ORCA CHAIR

BY STUDIO GUD





ORCA CHAIR

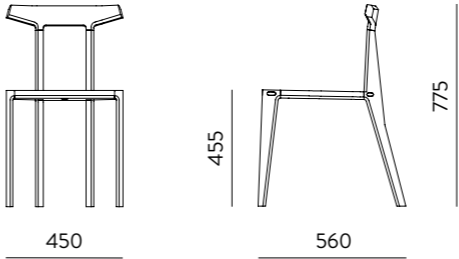

by **STUDIO GUD**, 2012

Orca is an all-wood chair, that achieves lightness and elegance through design, but also strength and comfort through materials and craft techniques. The sculptural backrest is inspired by the fin of an orca.

DIMENSIONS
W 450 H 775 D 560

MATERIALS
STRUCTURE SOLID WOOD
SEAT PAD LEATHER (OPTIONAL)

WOOD
OAK NATURA
OAK WHITE OIL
OAK SMOKED OPEN PORE
OAK GOLDEN BROWN
WALNUT NATURA
WALNUT UV PROTECT

REFERENCES
WCDGU001C OAK
WCDGU001N WALNUT
WCDGU001CP OAK/LEATHER
WCDGU001NP WALNUT/LEATHER

PRODUCT SHEET DOWNLOAD
WEWOOD.EU



PALA CHAIR

BY RAMOS BASSOLS





PALA CHAIR

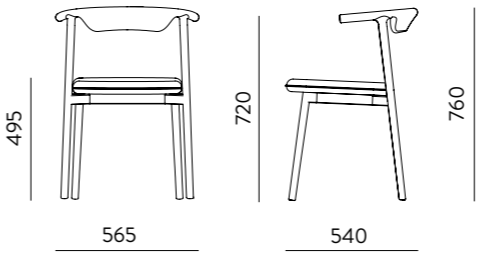

by RAMOS BASSOLS, 2018

Kundera is an all-wood chair that explores the dialectic between weight and lightness. On one hand, the elegance of the design elevates it, and on the other, the weight and strength of solid wood make it closer to the earth.

DIMENSIONS
W 565 H 760 D 540

MATERIALS
STRUCTURE SOLID WOOD
SEAT FABRICS | LEATHERS

WOOD
OAK NATURA
OAK WHITE OIL
OAK SMOKED OPEN PORE
OAK GOLDEN BROWN
WALNUT NATURA
WALNUT UV PROTECT

REFERENCES
WCDB001C OAK
WCDB001N WALNUT

PRODUCT SHEET DOWNLOAD
WEWOOD.EU



VIO CHAIR

BY CHRISTIAN HAAS





VIO CHAIR

NEW

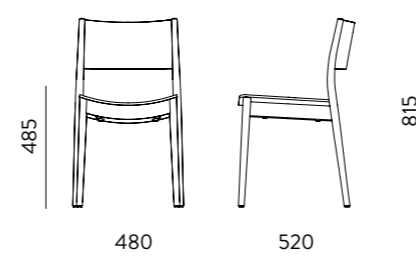

by CHRISTIAN HAAS, 2026

Vio is a versatile wooden chair, available in upholstered or non-upholstered versions. The construction is reduced to its essential elements, ensuring visual lightness, structural integrity and lasting ergonomic quality. Also available with armrests.

DIMENSIONS
W 480 H 815 D 520

REFERENCES
WCDCH03C CHAIR OAK
WCDCH03N CHAIR WALNUT
WCDCH04C CHAIR OAK/FABRICS | LEATHER
WCDCH04N CHAIR WALNUT/FABRICS | LEATHER

MATERIALS
STRUCTURE SOLID WOOD
SEAT | BACK PLAYWOOD | FABRICS | LEATHERS

WOOD
OAK NATURA
OAK WHITE OIL
OAK SMOKED OPEN PORE
OAK GOLDEN BROWN
WALNUT NATURA
WALNUT UV PROTECT

PRODUCT SHEET DOWNLOAD
WEWOOD.EU





VIO ARMCHAIR

BY CHRISTIAN HAAS





VIO ARMCHAIR

NEW

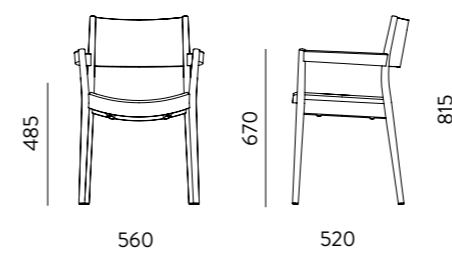

by CHRISTIAN HAAS, 2026

Vio is a versatile wooden armchair, available in upholstered or non-upholstered versions. The construction is reduced to its essential elements, ensuring visual lightness, structural integrity and lasting ergonomic quality. Also available without armrests.

DIMENSIONS
W 560 H 815 D 520

REFERENCES
WCDCH005C ARMCHAIR OAK
WCDCH005N ARMCHAIR WALNUT
WCDCH006C ARMCHAIR OAK/FABRICS | LEATHERW
CDCH006N ARMCHAIR WALNUT/FABRICS | LEATHER

MATERIALS
STRUCTURE SOLID WOOD
SEAT | BACK PLAYWOOD | FABRICS | LEATHERS

WOOD
OAK NATURA
OAK WHITE OIL
OAK SMOKED OPEN PORE
OAK GOLDEN BROWN
WALNUT NATURA
WALNUT UV PROTECT

PRODUCT SHEET DOWNLOAD
WEWOOD.EU



DESKS & CONSOLES

BRIDGE DESK

BY CHRISTOPHE DE SOUSA





BRIDGE DESK

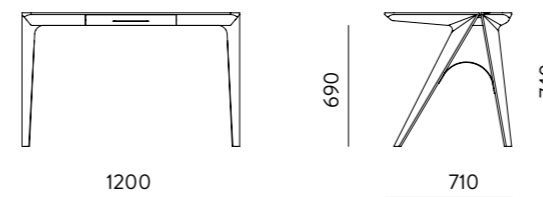

by CHRISTOPHE DE SOUSA, 2018

Bridge desk is inspired by the city of Porto, the only city in Europe with 6 bridges. It features smooth, rounded surfaces and an overall minimalist aesthetic. The steel arcs that span the legs reminds us of the structures on the bridges in Porto.

DIMENSIONS
W 1200 H 740 D 710

MATERIALS
TOP OAK | WANUT VENEER
STRUCTURE SOLID WOOD
STRUCTURE MARBLE | STONE

WOOD
OAK NATURA
OAK WHITE OIL
OAK SMOKED OPEN PORE
OAK GOLDEN BROWN
WALNUT NATURA
WALNUT UV PROTECT

REFERENCES
WSCCS001C OAK
WSCCS001N WALNUT

PRODUCT SHEET DOWNLOAD
WEWOOD.EU



METIS DESK

BY GONÇALO CAMPOS





METIS DESK

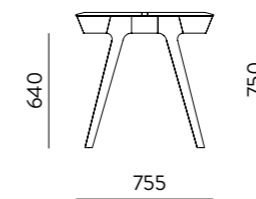
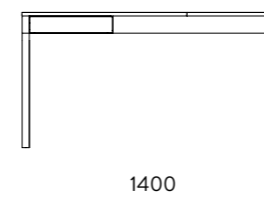

by GONÇALO CAMPOS, 2015

Metis is a compact desk made of solid wood, offering a real storage solution. This desk helps you to keep your workspace tidy and organized with three drawers, one secret compartment, and two lidded sections. It is the perfect minimalistic office desk.

DIMENSIONS
W 1400 H 750 D 755

MATERIALS
STRUCTURE SOLID WOOD
TOP MARBLE | STONE

WOOD
OAK NATURA
OAK WHITE OIL
OAK SMOKED OPEN PORE
OAK GOLDEN BROWN
WALNUT NATURA
WALNUT UV PROTECT

REFERENCES
WSCGC001C OAK
WSCGC001N WALNUT

PRODUCT SHEET DOWNLOAD
WEWOOD.EU



RE-FORM CONSOLE

BY ALAIN GILLES





RE-FORM CONSOLE

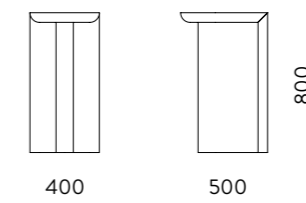
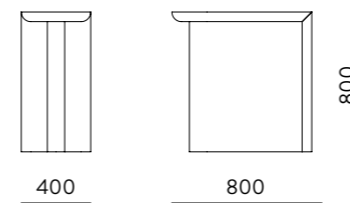

by ALAIN GILLES, 2024

Re-Form console is an exciting extension of the Re-Form tables, encapsulating the very essence of formation and transformation. It skillfully melds distinct elements to craft cohesive wholes and unexpected, evolving combinations. Available in two different dimensions.

DIMENSIONS
W 500 H 800 D 400
W 800 H 800 D 400

MATERIALS
TOP OAK | WANUT VENEER
STRUCTURE SOLID WOOD

WOOD
OAK NATURA
OAK WHITE OIL
OAK SMOKED OPEN PORE
OAK GOLDEN BROWN
WALNUT NATURA
WALNUT UV PROTECT

REFERENCES
WSCAG001C OAK SMALL
WSCAG001N WALNUT SMALL
WSCAG002C OAK LARGE
WSCAG002N WALNUT LARGE

PRODUCT SHEET DOWNLOAD
WEWOOD.EU



SOFAS



BOWIE SOFA

BY GONÇALO CAMPOS



BOWIE SOFA

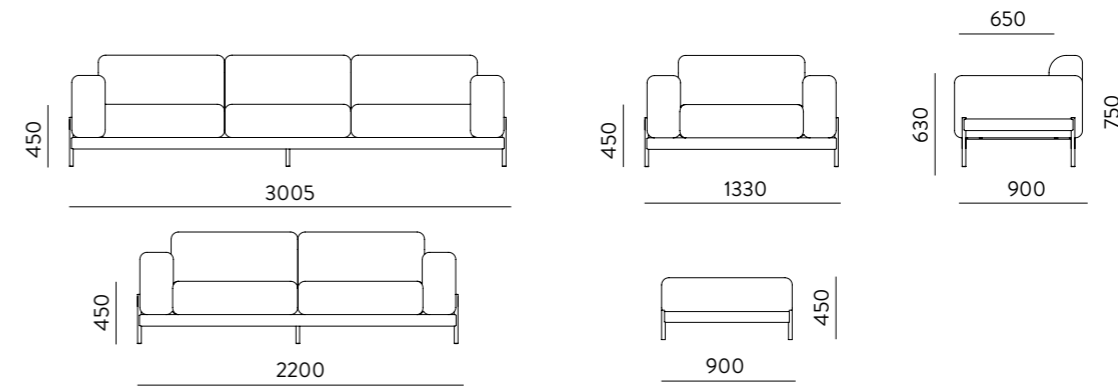

by GONÇALO CAMPOS, 2017

Bowie is a soft balanced sofa designed to be pleasing and comfortable, to fit equally well in a living room, as in a hotel lobby. With a simple eye-catching detail, the structure of the sofa plays between the slim appearance of metal and the robustness of wood. It is available in different dimensions: three seats, two seats, one seat and ottoman.

DIMENSIONS

3 SEATS: W 3005 H 750 D 900
 2 SEATS: W 2200 H 750 D 900
 1 SEAT: W 1130 H 750 D 900
 OTTOMAN: W 900 H 450 D 900

MATERIALS

STRUCTURE METAL
DETAIL SOLID WOOD
SEAT FABRICS | LEATHERS

WOOD

OAK NATURA
OAK WHITE OIL
OAK SMOKED OPEN PORE
OAK GOLDEN BROWN
WALNUT NATURA
WALNUT UV PROTECT

REFERENCES

WSFGC003C 3 SEATS OAK
WSFGC003N 3 SEATS WALNUT
WSFGC002C 2 SEATS OAK
WSFGC002N 2 SEATS WALNUT
WSFGC001C 1 SEAT OAK
WSFGC001N 1 SEAT WALNUT
WSFGC000C OTTOMAN OAK
WSFGC000N OTTOMAN WALNUT

PRODUCT SHEET DOWNLOAD
 WEWOOD.EU





DOME MODULAR SOFA

BY ERNO DIERCKX



DOME MODULAR SOFA

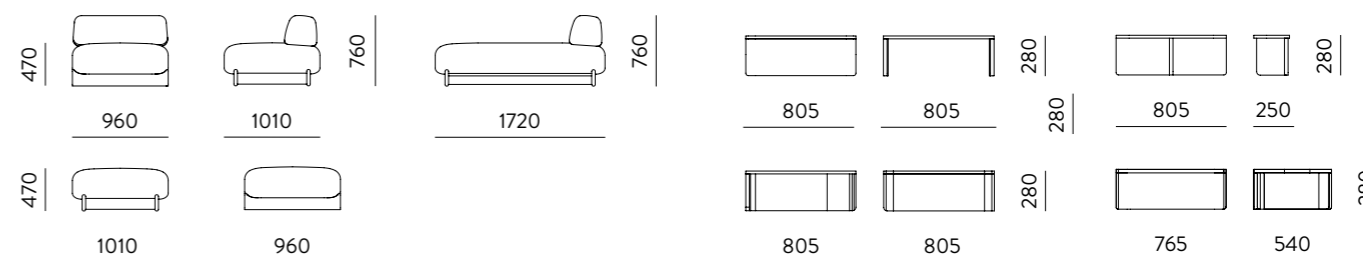

by ERNO DIERCKX, 2024

Dome is a modular sofa that prioritises comfort without sacrificing definitive form and aesthetic. It is composed by a set of six components: an ottoman, an one seater module and a chaise longue, as well as a complementary wooden corner module, a center module and a side module. This is a modular seating system with almost unlimited possible configurations allowing for flexible compositions to suit unique spaces.

DIMENSIONS

1 SEAT: W 960 H 760 D 1010

CHAISE LONGUE: W 960 H 760 D 1720

OTTOMAN: W 960 H 470 D 1010

CENTER MODULE: W 805 H 280 D 805

SIDE MODULE: W 805 H 280 D 250

CORNER MODULE: W 805 H 280 D 805

ROUNDED CORNER MODULE: W 540 H 280 D 765

MATERIALS

STRUCTURE SOLID WOOD
SEAT FABRICS | LEATHERS

WOOD

OAK NATURA
OAK WHITE OIL
OAK SMOKED OPEN PORE
OAK GOLDEN BROWN
WALNUT NATURA
WALNUT UV PROTECT

REFERENCES

WSFED001C 1 SEAT OAK
WSFED001N 1 SEAT WALNUT
WSFED002C CHAISE LONGUE OAK
WSFED002N CHAISE LONGUE WALNUT
WSFED003C OTTOMAN OAK
WSFED003N OTTOMAN WALNUT
WSFED004C CENTER MODULE OAK
WSFED004N CENTER MODULE WALNUT
WSFED005C SIDE MODULE OAK
WSFED005N SIDE MODULE WALNUT
WSFED006C CORNER MODULE OAK
WSFED006N CORNER MODULE WALNUT
WSFED007C ROUNDED MODULE OAK
WSFED007N ROUNDED MODULE WALNUT

PRODUCT SHEET DOWNLOAD
WEWOOD.EU





SCAFFOLD SOFA

BY ANDRÉ TEOMAN STUDIO







SCAFFOLD SOFA

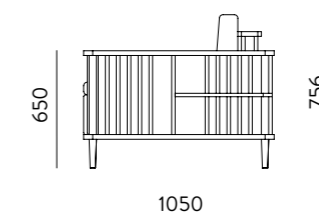
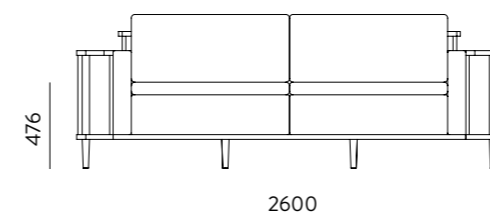

by ANDRÉ TEOMAN STUDIO, 2015

Scaffold is a comfortable sofa with a surrounding wooden frame which can be used as a bookshelf or as a division, showing the best of the high-end joinery.

DIMENSIONS
W 2600 H 756 D 1050

MATERIALS
STRUCTURE SOLID WOOD
SEAT | BACK FABRICS | LEATHERS
CUSHIONS FABRICS | LEATHERS

WOOD
OAK NATURA
OAK WHITE OIL
OAK SMOKED OPEN PORE
OAK GOLDEN BROWN
WALNUT NATURA
WALNUT UV PROTECT

REFERENCES
WSFAT001C OAK
WSFAT001N WALNUT

PRODUCT SHEET DOWNLOAD
WEWOOD.EU



STORAGE



BRUTALIST SIDEBOARD

BY ERNO DIERCKX





BRUTALIST SIDEBOARD

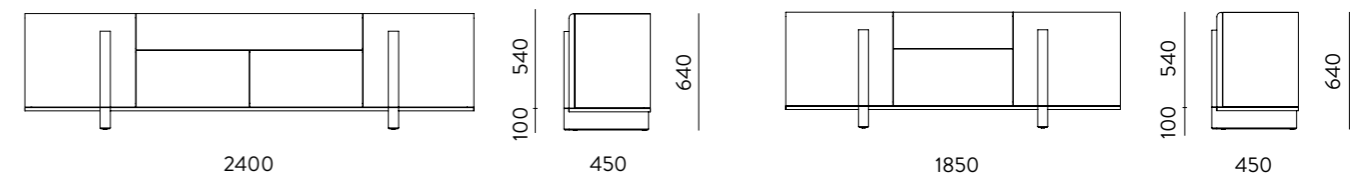

by ERNO DIERCKX, 2023

Brutalist is a remarkable sideboard inspired by brutalist design. It embraces daring geometric shapes and a clean, minimalist allure. It features two doors housing adjustable shelves within, alongside two middle drawers, offering ample storage possibilities for a diverse array of items.

DIMENSIONS
W 1850 H 640 D 450
W 2400 H 640 D 450

MATERIALS
STRUCTURE SOLID WOOD

WOOD
OAK NATURA
OAK WHITE OIL
OAK SMOKED OPEN PORE
OAK GOLDEN BROWN
WALNUT NATURA
WALNUT UV PROTECT

REFERENCES
WAPED001C OAK 1850
WAPED001N WALNUT 1850
WAPED002C OAK 2400
WAPED002N WALNUT 2400

PRODUCT SHEET DOWNLOAD
WEWOOD.EU



CAROUSEL SIDEBOARD

BY LEONHARD PFEIFER





CAROUSEL SIDEBOARD

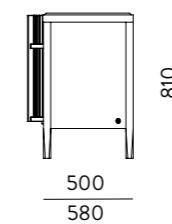
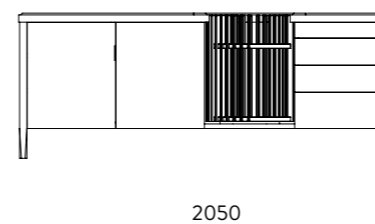

by LEONHARD PFEIFER, 2016

Carousel is a sophisticated sideboard that combines noble wood and marble. It features two folding doors with internal wooden shelves and four drawers with tic-tac system. The focal point is its turntable in the middle which can be used for bottles and glasses.

DIMENSIONS
W 2050 H 810 D 580

MATERIALS
STRUCTURE OAK | WALNUT VENEER
TOP MARBLE
DETAILS MIRROR | LEATHER

WOOD
OAK NATURA
OAK WHITE OIL
OAK SMOKED OPEN PORE
OAK GOLDEN BROWN
WALNUT NATURA
WALNUT UV PROTECT

REFERENCES
WAPLP401CM OAK STANDARD MARBLE
WAPLP401NM WALNUT STANDARD MARBLE
WAPLP401CMP OAK PREMIUM MARBLE
WAPLP401NMP WALNUT PREMIUM MARBLE

PRODUCT SHEET DOWNLOAD
WEWOOD.EU





CONTADOR SIDEBOARD

BY WEWOOD



CONTADOR SIDEBOARD ANNIVERSARY EDITION 2022

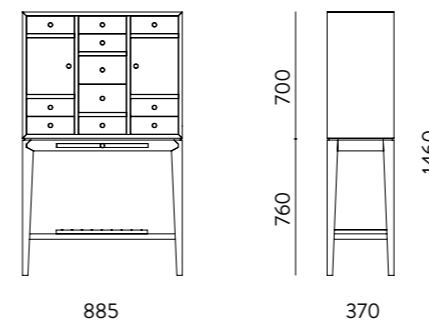

by WEWOOD, 2022

A special edition of Contador sideboard limited to 10 units with brass and leather details created to celebrate the 10 years anniversary of Wewood. It is composed of drawers and doors of different dimensions that makes it the perfect organizer for different uses and spaces.

DIMENSIONS
W 885 H 1460 D 370

MATERIALS
STRUCTURE WALNUT SOLID
DETAILS RED LEATHER | BRASS

WOOD
OAK NATURA
OAK WHITE OIL
OAK SMOKED OPEN PORE
OAK GOLDEN BROWN
WALNUT NATURA
WALNUT UV PROTECT

REFERENCES
WAPWW306N WALNUT SPECIAL

PRODUCT SHEET DOWNLOAD
WEWOOD.EU



CONTADOR II SIDEBOARD

BY WEWOOD





CONTADOR SIDEBOARD II

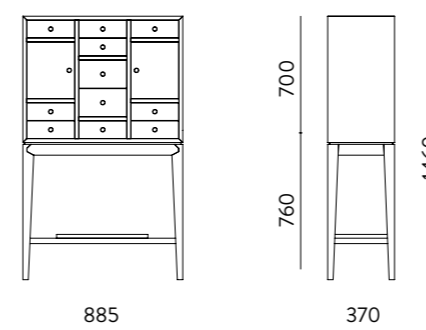

by WEWOOD, 2022

Contador is a timeless piece inspired by traditional Portuguese furniture whose original purpose was to provide practical storage space for dining rooms and offices. It is composed of drawers and doors of different dimensions that makes it the perfect organizer for different uses and spaces.

DIMENSIONS
W 885 H 1460 D 370

MATERIALS
STRUCTURE SOLID WOOD
DETAILS RED | GREEN LEATHER

WOOD
OAK NATURA
OAK WHITE OIL
OAK SMOKED OPEN PORE
OAK GOLDEN BROWN
WALNUT NATURA
WALNUT UV PROTECT

REFERENCES
WAPWW305C OAK
WAPWW305N WALNUT

PRODUCT SHEET DOWNLOAD
WEWOOD.EU





MISTER SIDEBOARD

BY DANIEL DUARTE



MISTER SIDEBOARD

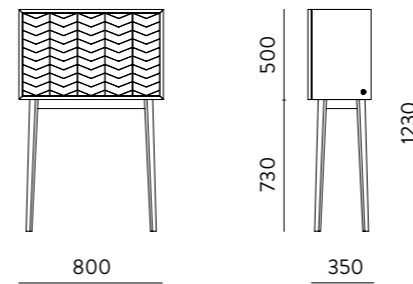

by DANIEL DUARTE, 2015

Mister excels for its elegant design and attention to details, as the herringbone pattern of the door. Designed for people and environments in constant change, it stands out for its versatility and customization. It can also be used as a bar or a desk.

DIMENSIONS
W 800 H 1230 D 350

MATERIALS
STRUCTURE WALNUT SOLID
DOOR PANEL OAK SOLID

WOOD
OAK NATURA
OAK WHITE OIL
OAK SMOKED OPEN PORE
OAK GOLDEN BROWN
WALNUT NATURA
WALNUT UV PROTECT

REFERENCES
WAPDD101N WALNUT

PRODUCT SHEET DOWNLOAD
WEWOOD.EU



RADIO MEDIA UNIT

BY WEWOOD





RADIO MEDIA UNIT

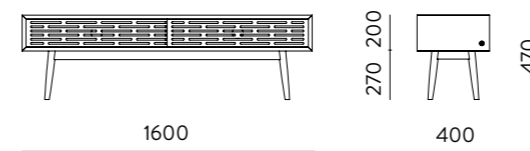

by WEWOOD, 2015

Radio is the perfect solution to keep multimedia devices. The perforated sliding doors across the front, make possible the use of the remote control, even when the doors are closed. The hole in the back allows the passage of cables.

DIMENSIONS
W 1600 H 470 D 400

MATERIALS
STRUCTURE SOLID WOOD

WOOD
OAK NATURA
OAK WHITE OIL
OAK SMOKED OPEN PORE
OAK GOLDEN BROWN
WALNUT NATURA
WALNUT UV PROTECT

REFERENCES
WAPWW203C OAK
WAPWW203N WALNUT

PRODUCT SHEET DOWNLOAD
WEWOOD.EU



SCARPA SIDEBOARD

BY WEWOOD





SCARPA SIDEBOARD

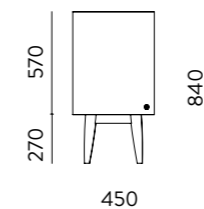
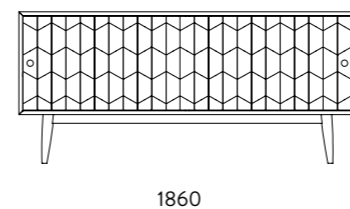

by WEWOOD, 2015

Scarpa is a sideboard with a unique design, offering two drawers and four divisions with a great and useful area, allowing to store any type of objects. The pieces of wood on the doors create a dynamic game that results in a three-dimensional pattern.

DIMENSIONS
W 1860 H 840 D 450

MATERIALS
STRUCTURE SOLID WOOD

WOOD
OAK NATURA
OAK WHITE OIL
OAK SMOKED OPEN PORE
OAK GOLDEN BROWN
WALNUT NATURA
WALNUT UV PROTECT

REFERENCES
WAPWW201C OAK
WAPWW201TN WALNUT

PRODUCT SHEET DOWNLOAD
WEWOOD.EU



TOUCH CHEST OF DRAWERS

BY SURICATA DESIGN STUDIO





TOUCH CHEST OF DRAWERS

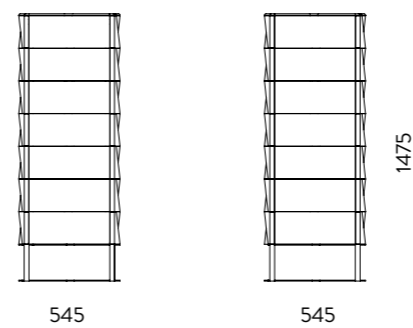

by SURICATA DESIGN STUDIO, 2012

Touch is a chest of drawers with a round-shaped silhouette that reveals the wood flexibility and beauty and wakens the desire of feeling its shape by touch. Designed for storage purposes, this object appeals to our senses and to the most sophisticated tastes.

DIMENSIONS
W 545 H 1475 D 545

MATERIALS
EXTERIOR SOLID WOOD
INTERNAL STRUCTURE OAK | WALNUT MDF
LEGS METAL

WOOD
OAK NATURA
OAK WHITE OIL
OAK SMOKED OPEN PORE
OAK GOLDEN BROWN
WALNUT NATURA
WALNUT UV PROTECT

REFERENCES
WAPSD101C OAK
WAPSD101N WALNUT

PRODUCT SHEET DOWNLOAD
WEWOOD.EU



TABLES

ANCHOR DINING TABLE

BY DAN YEFFET





ANCHOR DINING TABLE

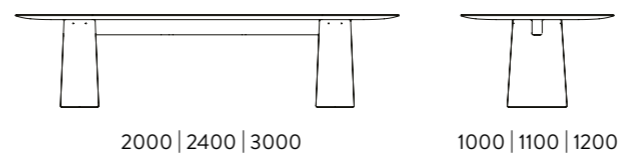

by DAN YEFFET, 2025

Anchor is a luxurious dining table available in three sizes, featuring a wood top supported by two rounded Travertine legs.

DIMENSIONS
W 2000 H 730 D 1000
W 2400 H 730 D 1100
W 3000 H 730 D 1200

MATERIALS
TOP SOLID WOOD
BASE TRAVERTINE

WOOD
OAK NATURA
OAK WHITE OIL
OAK SMOKED OPEN PORE
OAK GOLDEN BROWN
WALNUT NATURA
WALNUT UV PROTECT

REFERENCES
WMJDY002CT OAK 2000
WMJDY002NT WALNUT 2000
WMJDY003CT OAK 2400
WMJDY003NT WALNUT 2400
WMJDY004CT OAK 3000
WMJDY004NT WALNUT 3000

PRODUCT SHEET DOWNLOAD
 WEWOOD.EU



ANCHOR TABLES

BY DAN YEFFET





ANCHOR COFFEE | SIDE TABLES

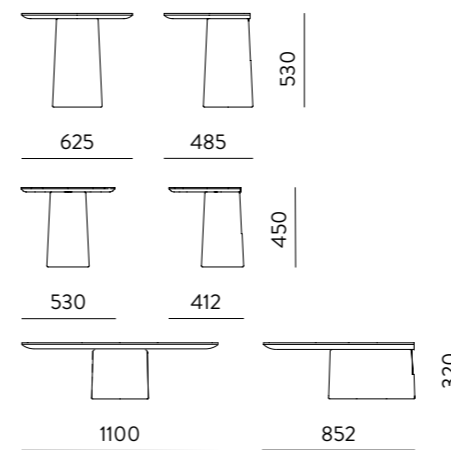

DIMENSIONS
W 625 H 530 D 485
W 530 H 450 D 412
W 1100 H 320 D 852

REFERENCES
WMCDY001C TALL SIDE TABLE OAK
WMCDY001N TALL SIDE TABLE WALNUT
WMCDY001CT TALL SIDE TABLE TRAVERTINE/OAK
WMCDY001NT TALL SIDE TABLE TRAVERTINE/WALNUT
WMCDY002C SIDE TABLE OAK
WMCDY002N SIDE TABLE WALNUT
WMCDY002CT SIDE TABLE TRAVERTINE/OAK
WMCDY002NT SIDE TABLE TRAVERTINE/WALNUT
WMCDY003NT COFFEE TABLE TRAVERTINE/OAK
WMCDY003NT COFFEE TABLE TRAVERTINE/WALNUT

MATERIALS
TOP SOLID WOOD
BASE OAK | WALNUT | VENEER
 OR TRAVERTINE

WOOD
OAK NATURA
OAK WHITE OIL
OAK SMOKED OPEN PORE
OAK GOLDEN BROWN
WALNUT NATURA
WALNUT UV PROTECT

by DAN YEFFET, 2025

Anchor is a set of tables comprising two side tables and a coffee table, crafted from a combination of wood and stone that adds depth and versatility, making it adaptable to a variety of interior styles.

PRODUCT SHEET DOWNLOAD
WEWOOD.EU





AMOS DINING TABLE

BY CHRISTIAN HAAS



AMOS DINING TABLE

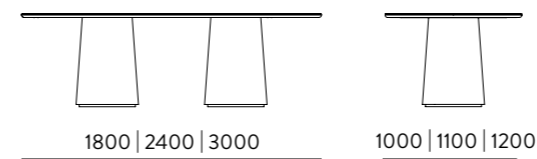

by CHRISTIAN HAAS, 2023

Amos is an organic and defined wood table. With a solid wood top and a conical wooden base with a soft touch and sculptural appearance. Three sizes are available in oak or walnut.

DIMENSIONS
W 1800 H 750 D 1000
W 2400 H 750 D 1100
W 3000 H 750 D 1200

MATERIALS
TOP SOLID WOOD
BASE OAK | WALNUT VENEER

WOOD
OAK NATURA
OAK WHITE OIL
OAK SMOKED OPEN PORE
OAK GOLDEN BROWN
WALNUT NATURA
WALNUT UV PROTECT

REFERENCES
WMJCH004C OAK1800
WMJCH004N WALNUT 1800
WMJCH005C OAK 2400
WMJCH005N WALNUT 2400
WMJCH006C OAK 3000
WMJCH006N WALNUT 3000

PRODUCT SHEET DOWNLOAD
 WEWOOD.EU





AMOS TABLES

BY CHRISTIAN HAAS



AMOS COFFEE | SIDE TABLES

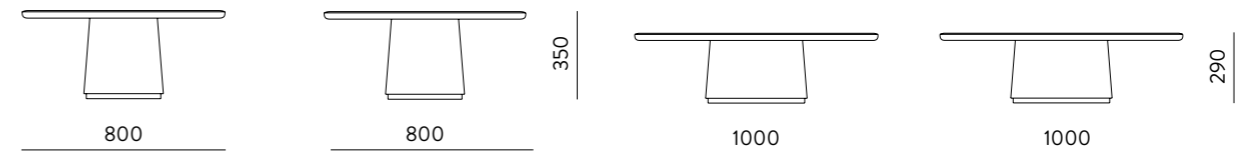

by CHRISTIAN HAAS, 2023

Amos is a set of two tables with different dimensions that are inspired by the Amos dining table. It can be used as a single side table or combined. The two tables are overlapped to create a dynamic living room coffee table with two shapes and heights.

DIMENSIONS
W 800 H 350 D 800
W 1000 H 290 D 1000

MATERIALS
TOP SOLID WOOD
BASE OAK | WALNUT VENEER

WOOD
OAK NATURA
OAK WHITE OIL
OAK SMOKED OPEN PORE
OAK GOLDEN BROWN
WALNUT NATURA
WALNUT UV PROTECT

REFERENCES
WMCCH001C MEDIUM TABLE OAK
WMCCH001N MEDIUM TABLE WALNUT
WMCCH002C LARGE TABLE OAK
WMCCH002N LARGE TABLE WALNUT

PRODUCT SHEET DOWNLOAD
WEWOOD.EU





CORNER COFFEE TABLES

BY PIERRE DUBOURG

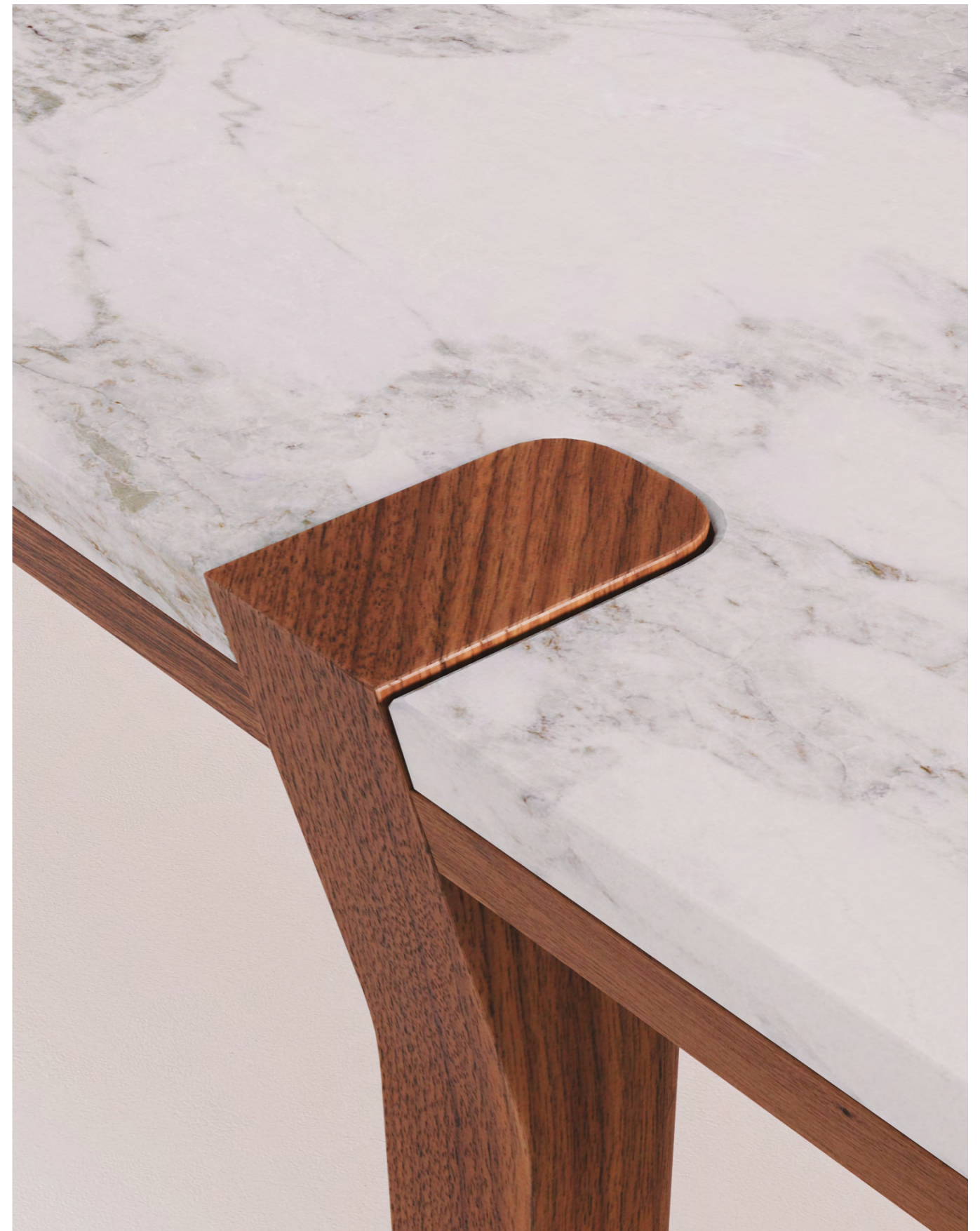



CORNER COFFEE TABLES

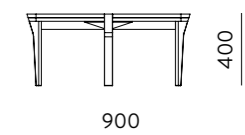
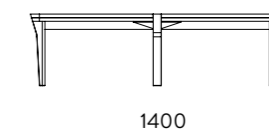
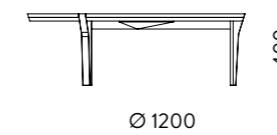
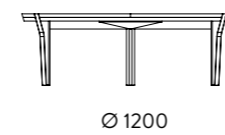

by PIERRE DUBOURG, 2019

Corner tables were designed to disrupt the classic position of the legs of most of the tables, putting it on a particular position that assures the stability and leaves the corners free. The different forms and materials available make it possible to adapt it to the look & feel of the space.

DIMENSIONS

Ø 1200 H 400
W 1400 H 400 D 900

REFERENCES

WMCPD001C ROUND TABLE OAK STANDARD MARBLE
WMCPD001N ROUND TABLE WALNUT STANDARD MARBLE
WMCPD001CP ROUND TABLE OAK PREMIUM MARBLE
WMCPD001NP ROUND TABLE WALNUT PREMIUM MARBLE
WMCPD002C RECTANGULAR TABLE OAK STANDARD MARBLE
WMCPD002N RECTANGULAR TABLE WALNUT STANDARD MARBLE
WMCPD002CP RECTANGULAR TABLE OAK PREMIUM MARBLE
WMCPD002NP RECTANGULAR TABLE WALNUT PREMIUM MARBLE

MATERIALS

LEGS SOLID WOOD
STRUCTURE OAK | WALNUT VENEER
TOP MARBLE

WOOD

OAK NATURA
OAK WHITE OIL
OAK SMOKED OPEN PORE
OAK GOLDEN BROWN
WALNUT NATURA
WALNUT UV PROTECT

PRODUCT SHEET DOWNLOAD
 WEWOOD.EU



CRIADO-MUDO BEDSIDE

BY WEWOOD





CRIADO-MUDO BEDSIDE TABLE

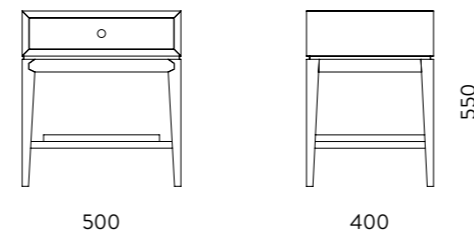

by WEWOOD, 2024

Criado-mudo bedside table is a stunning piece of solid wood furniture, drawing inspiration from the timeless design of our iconic Contador sideboard. It features a practical drawer and a convenient tray in its base.

DIMENSIONS
W 500 H 550 D 400

MATERIALS
STRUCTURE SOLID WOOD

WOOD
OAK NATURA
OAK WHITE OIL
OAK SMOKED OPEN PORE
OAK GOLDEN BROWN
WALNUT NATURA
WALNUT UV PROTECT

REFERENCES
WBTWW001C OAK
WBTWW001N WALNUT

PRODUCT SHEET DOWNLOAD
WEWOOD.EU



DUPLEX & TRIPLEX BEDSIDE

BY CHRISTIAN HAAS



DUPLEX BEDSIDE TABLE

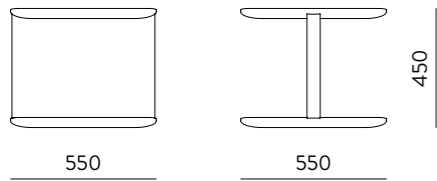

by CHRISTIAN HAAS, 2024

Duplex side | bedside table is part of a set of tables where rounded edges seamlessly blend style and functionality. Crafted from solid wood and designed to enhance both living rooms and bedrooms, establishing a unified aesthetic.

DIMENSIONS
W 550 H 450 D 550

MATERIALS
TOP | BASE SOLID WOOD
STRUCTURE OAK | WALNUT VENEER

WOOD
OAK NATURA
OAK WHITE OIL
OAK SMOKED OPEN PORE
OAK GOLDEN BROWN
WALNUT NATURA
WALNUT UV PROTECT

REFERENCES
WBTC001C OAK
WBTC001N WALNUT

PRODUCT SHEET DOWNLOAD
WEWOOD.EU



TRIPLEX BEDSIDE TABLE

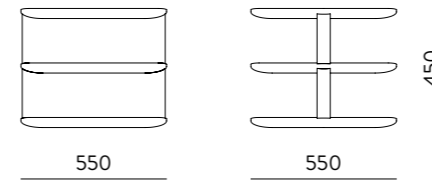

by CHRISTIAN HAAS, 2024

Triplex side | bedside table is part of a stylish and functional multipurpose table set. Crafted from solid wood and purposefully designed to complement both living rooms and bedrooms, creating a cohesive aesthetic.

DIMENSIONS
W 550 H 450 D 550

MATERIALS
TOP | BASE SOLID WOOD
STRUCTURE OAK | WALNUT VENEER

WOOD
OAK NATURA
OAK WHITE OIL
OAK SMOKED OPEN PORE
OAK GOLDEN BROWN
WALNUT NATURA
WALNUT UV PROTECT

REFERENCES
WBTC002C OAK
WBTC002N WALNUT

PRODUCT SHEET DOWNLOAD
WEWOOD.EU





HEXA TABLE

BY DANIEL VIEIRA





HEXA COFFEE | SIDE TABLE

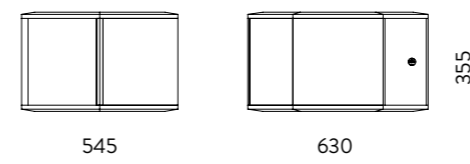

by DANIEL VIEIRA, 2012

Hexa stands out for its modernist aesthetics and its functional character. The modular design allows it to fit into different spaces. In small rooms, it can be used only one module, while in larger spaces it's possible to combine several modules in different types of wood.

DIMENSIONS
W 545 H 355 D 630

MATERIALS
STRUCTURE SOLID WOOD

WOOD
OAK NATURA
OAK WHITE OIL
OAK SMOKED OPEN PORE
OAK GOLDEN BROWN
WALNUT NATURA
WALNUT UV PROTECT

REFERENCES
WMCDV001C OAK
WMCDV001N WALNUT

PRODUCT SHEET DOWNLOAD
WEWOOD.EU





KAYA TABLES

BY ÜMIT ÇAĞLAR



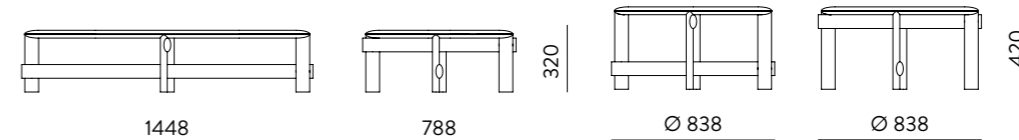

by ÜMIT ÇAĞLAR 2026

Kaya coffee table is a quite meditation on craftsmanship and spatial harmony, combining a solid wood structure with a marble top and brass details.

DIMENSIONS
W 1448 H 320 D 788
W 838 H 420 D 838

REFERENCES
WMCUC001C OVAL COFFEE TABLE OAK STANDARD MARBLE
WMCUC001N OVAL COFFEE TABLE WALNUT STANDARD MARBLE
WMCUC001CP OVAL COFFEE TABLE OAK PREMIUM MARBLE
WMCUC001NP OVAL COFFEE TABLE WALNUT PREMIUM MARBLE
WMCUC002C ROUND COFFEE TABLE OAK STANDARD MARBLE
WMCUC002N ROUND COFFEE TABLE WALNUT STANDARD MARBLE
WMCUC002CP ROUND COFFEE TABLE OAK PREMIUM MARBLE
WMCUC002NP ROUND COFFEE TABLE WALNUT PREMIUM MARBLE

MATERIALS
STRUCTURE SOLID WOOD
TOP MARBLE

WOOD
OAK NATURA
OAK WHITE OIL
OAK SMOKED OPEN PORE
OAK GOLDEN BROWN
WALNUT NATURA
WALNUT UV PROTECT

PRODUCT SHEET DOWNLOAD
 WEWOOD.EU





MEMÓRIA COFFEE TABLE

BY WEWOOD



MEMÓRIA COFFEE TABLE

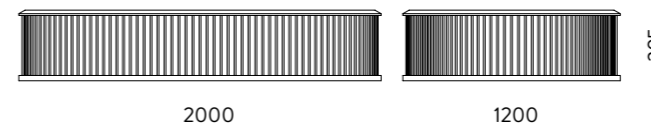

by WEWOOD, 2018

Memória is a coffee table with iron pipes and wood, both on bottom and top. A functional art piece with a touch of Mid-century and a modern twist for an eclectic feel. Memória means “memory” in English.

DIMENSIONS
W 2000 H 395 D 1200

MATERIALS
STRUCTURE SOLID WOOD

WOOD
OAK NATURA
OAK WHITE OIL
OAK SMOKED OPEN PORE
OAK GOLDEN BROWN
WALNUT NATURA
WALNUT UV PROTECT

REFERENCES
WMCWW003CF OAK VENEERED
WMCWW003NF WALNUT VENEERED

PRODUCT SHEET DOWNLOAD
WEWOOD.EU





NURIA EXTENDABLE TABLE

BY GONÇALO CAMPOS





NURIA EXTENDABLE TABLE

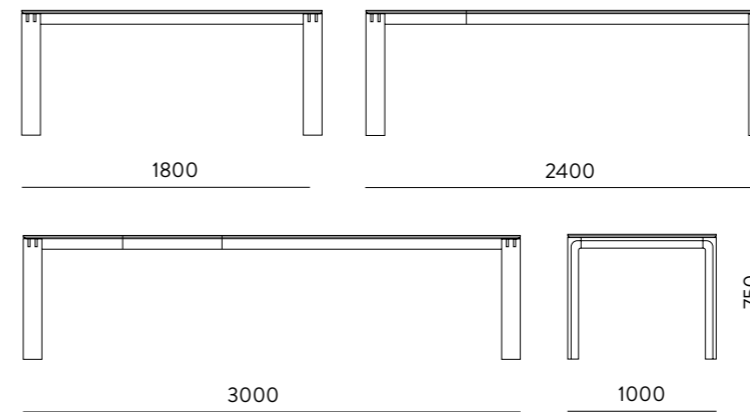

by GONÇALO CAMPOS, 2025

Nuria is an extendable dining table with a solid construction that expands from 6 to 10 seating places. The proportions and joinery details highlight the work involved in building such a piece with a balance of soft curves and angled lines.

DIMENSIONS
W 1800 + 2*600 H 750 D 1000

MATERIALS
TOP OAK | WALNUT VENEER
STRUCTURE SOLID WOOD

WOOD
OAK NATURA
OAK WHITE OIL
OAK SMOKED OPEN PORE
OAK GOLDEN BROWN
WALNUT NATURA
WALNUT UV PROTECT

REFERENCES
WMJGC015C OAK
WMJGC015N WALNUT

PRODUCT SHEET DOWNLOAD
WEWOOD.EU



RAIA DINING TABLE

BY STUDIO GUD





RAIA DINING TABLE

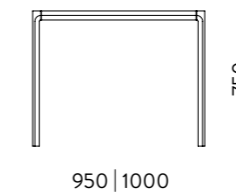
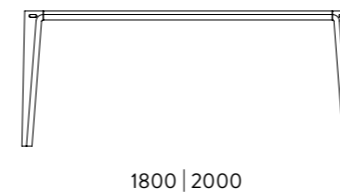

by STUDIO GUD, 2012

Raia is a functional and versatile wooden table that manages to transmit lightness and elegance despite its solid construction. It can also be used as a desk.

DIMENSIONS
W 1800 H 750 D 950
W 2000 H 750 D 1000

MATERIALS
STRUCTURE SOLID WOOD

WOOD
OAK NATURA
OAK WHITE OIL
OAK SMOKED OPEN PORE
OAK GOLDEN BROWN
WALNUT NATURA
WALNUT UV PROTECT

REFERENCES
WMJGU001C OAK 1800
WMJGU001N WALNUT 1800
WMJGU002C OAK 2000
WMJGU002N WALNUT 2000

PRODUCT SHEET DOWNLOAD
WEWOOD.EU



RE-FORM TABLES

BY ALAIN GILLES





RE-FORM COFFEE | SIDE TABLES

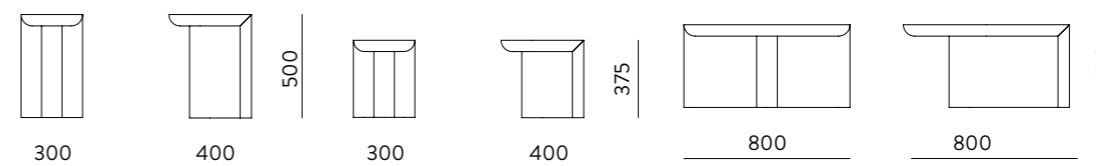

by ALAIN GILLES, 2023

Re-Form is a series of tables available in three different sizes, skillfully combining elements to create cohesive wholes or unexpected and evolutionary blends, designed to provide utmost versatility as either standalone pieces or artistic combinations.

DIMENSIONS
W 300 H 500 D 400
W 300 H 375 D 400
W 800 H 400 D 800

MATERIALS
STRUCTURE SOLID WOOD

WOOD
OAK NATURA
OAK WHITE OIL
OAK SMOKED OPEN PORE
OAK GOLDEN BROWN
WALNUT NATURA
WALNUT UV PROTECT

REFERENCES
WMCAG001C TALL SIDE TABLE OAK
WMCAG001N TALL SIDE TABLE WALNUT
WMCAG002C SIDE TABLE OAK
WMCAG002N SIDE TABLE WALNUT
WMCAG003C COFFEE TABLE OAK
WMCAG003N COFFEE TABLE WALNUT

PRODUCT SHEET DOWNLOAD
 WEWOOD.EU





SOMA DINING TABLE

BY CHRISTIAN HAAS



SOMA DINING TABLE

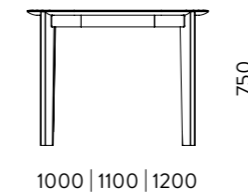
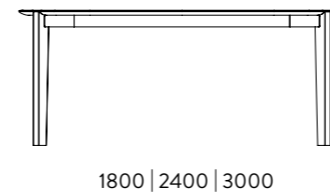

by CHRISTIAN HAAS, 2018

Soma is a balanced dining table that breathes generosity by its proportions and delicacy. Its curved outline and its soft edges are a tactile pleasure.

DIMENSIONS
W 1800 H 750 D 1000
W 2400 H 750 D 1100
W 3000 H 750 D 1200

MATERIALS
STRUCTURE SOLID WOOD

WOOD
OAK NATURA
OAK WHITE OIL
OAK SMOKED OPEN PORE
OAK GOLDEN BROWN
WALNUT NATURA
WALNUT UV PROTECT

REFERENCES
WMJCH001C OAK 1800
WMJCH001N WALNUT 1800
WMJCH002C OAK 2400
WMJCH002N WALNUT 2400
WMJCH003C OAK 3000
WMJCH003N WALNUT 3000

PRODUCT SHEET DOWNLOAD
WEWOOD.EU



VASCO DINING TABLE

BY VARIAFORMA





VASCO DINING TABLE

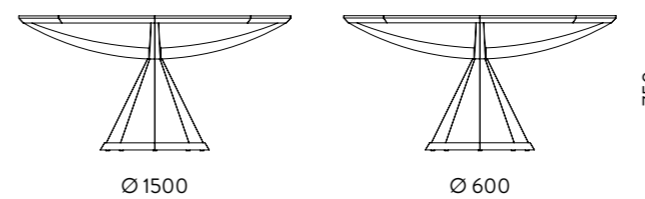

by VARIIFORMA, 2020

Vasco is a round table with a glass top that rests with extreme delicacy on a sculptural pedestal base that gives it harmony and creates the illusion of an object almost in a precarious balance.

DIMENSIONS
Ø 1500 H 750

MATERIALS
STRUCTURE OAK | WALNUT VENEER
TOP GLASS (BRONZE)

WOOD
OAK NATURA
OAK WHITE OIL
OAK SMOKED OPEN PORE
OAK GOLDEN BROWN
WALNUT NATURA
WALNUT UV PROTECT

REFERENCES
WMJVF001CV OAK GLASS
WMJVF001NV WALNUT GLASS

PRODUCT SHEET DOWNLOAD
WEWOOD.EU



DESIGNERS

ALAIN GILLES



Alain Gilles opened his own studio in late 2007 in order to pursue his own dreams and develop his personal approach to product design, furniture design, art direction and scenography.

Several of his products have been awarded international prizes, such as the Henry Van De Velde Label, the Design for Asia Golden Award, The "Red Dot Best of the Best" for the Welded table and the Good Design award for the Big Table.

In 2012, he was named "Designer of the Year" by the prestigious Interieur Kortrijk Fair.

ANDRÉ TEOMAN



André Teoman born in Viana do Castelo, Portugal in 1989, was raised between Viana do Castelo and Istanbul. Teoman took design classes in Viana do Castelo. His experience in the world of puppetry and theater also had an effect on his love for the fantasy world.

Making a difference at his hometown local artisans is now as important as to make meaningful projects. Preserve such craftsmanship is a mission and a desire to join their best craftsmanships with other great techniques that are being forgotten around the world. He creates his own world with wicked things and to turn them into a symbolization of distinctive taste and humor.

CHRISTIAN HAAS



Born in Germany in 1974, Christian Haas established his Studio in 2000. The Industrial Designer creates ever since products through multiple disciplines from furniture and lighting to porcelain and glassware.

His design approach merges simplicity and elegance. His sense of aesthetics is driven by the harmony between sobriety, usefulness, emotionality, longevity and uniqueness.

The Studio works for international brands such as Rosenthal, Karakter, Arita2016 and Tecta as well as for selected design galleries. Throughout the years, his work was honored with awards like the Red Dot Design Award and the Elle Decoration International Design Award.

CHRISTOPHE DE SOUSA



Franco-Portuguese Designer, Christophe de Sousa was born in France in 1979.

While still very young, he came to live in Portugal, the country of the origin of his parents.

This mixture of experiences allowed him a broad overview and understanding of the different cultures. Travelling, as well as living with people of different backgrounds, served as a foundation for his inspiration.

He showed a passion for drawing from an early age.

DANIEL DUARTE



Daniel Duarte is graduated in Interior Design and Equipment by School of Applied Arts of Castelo Branco in 2009.

In that same year, he moved to Madrid to join the multidisciplinary team Kawamura Ganjavian, where he developed several products and projects.

Back in Portugal he started in the company Wallshape and was one of the selected designers for integrating an eight months residency in the Programme More Design More Industry in Paredes.

DANIEL SOUSA



Born in 1977, Portugal. Graduated in Industrial Design at E.S.A.D., C.R. in 2000. Completed his formation attending several courses of different software, processes and technologies: furniture, stone, metal, ceramic and glass.

Between 2000 and 2002, teaches in high schools while working as a freelancer. From 2002 to 2007, works in design teams of different companies, mainly in the injected plastics technologies.

In 2007, co-founds the product design company, Diwiz, where he is been designing from house to kitchenware; home, garden and office furniture; to consumer electronics and industrial tools.

DANIEL VIEIRA



Daniel Vieira is a Portuguese product designer inspired by the beauty of everyday objects and industrial standards. Creates objects that combine utility and identity.

Motivated by the daily interactions among people and the objects around them, combines the visual and functional in his pragmatic design.

Over the years, it has developed products for Portuguese companies and has been invited to speak about design at different Portuguese universities and polytechnics. Now works as a professor, teaching Product Design. In 2009 he was awarded the “Daciano da Costa” which are the most prestigious Portuguese design award given to young product designers.

DAN YEFFET



Born in 1971 in Jerusalem, works and lives in Paris, France, since 2005.

Dan studied Industrial Design at Bezalel Academy: School of Art and Design in Jerusalem (1999-2001).

He then moved to the Netherlands where he graduated from the Gerrit Rietveld Academy in Amsterdam in 2002 (BA/MA in industrial/product design). After his graduation he set up his studio in Amsterdam.

In 2005 he moved his studio to Paris where he still works. Dan also holds a teaching position as design professor at the Ecole CAMONDO in Paris for the last decade.

DAVID GIRELLI



Swiss, but working in the UK, David Girelli is a rising star fast becoming renowned across Europe for his elegant contemporary pieces that echo Scandinavian design.

His experience in engineering, fashion, and interior design are clearly reflected in his notable furniture collections. Minimalistic style, bright textured fabrics and leathers, and interlocking geometric shapes characterize Girelli's pieces.

Traditional techniques on all joinery and the use of natural materials are also central to his design philosophy that promotes honesty and beauty.

ELEONORA FEDI



Eleonora Fedi is an interior designer. With a degree from the Politecnico di Milano (2012) and a master's from ESAD Matosinhos (2015), she currently collaborates with esad—idea, Research in Design and Art, as a researcher and designer responsible for the exhibition projects included in the Casa do Design Programme.

She has also been a member of the Porto Design Biennale team since the first edition, in 2019.

She was part of Wewood Design Centre from 2016 to 2019.

ERNO DIERCKX

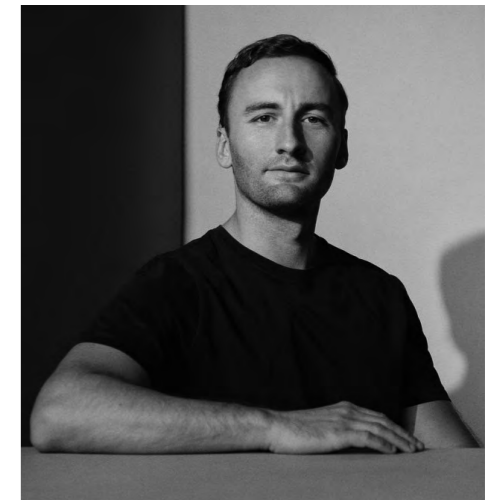

Erno Dierckx is an emerging Belgian product and furniture designer based in Barcelona, Spain.

As a designer, he challenges the manufacturing process and searches for clever and aesthetic solutions. He finds inspiration in the production process, materials, and construction of everyday objects.

Erno aims to create well-thought-out, timeless products that contribute to this world.

FABRÍCIO RONCA



Grew up in Belo Horizonte, Minas Gerais, Brazil, where he learned to see architecture, folklore and art in a playful and intimate way.

During his childhood he attended the Faculty of Fine Arts with his mother, where he learned to naturally appreciate drawing, painting and sculpture.

He has been working in the area since 2003 with architectural, interior and furniture and product design projects.

He seeks beauty, sustainability, balance of materials and affective memory in his works.

GONÇALO CAMPOS



Gonçalo Campos is a Portuguese product designer. Graduated in product Design in 2008, he soon after joined Fabrica, Benetton's communications research centre, in the design studio.

This gave him the chance to work with brands such as Secondome, Seletti or Zanotta. In 2009, he worked in Sam Baron's studio, after which started developing a series of objects, continuing to explore the possibilities of design through function and material.

Campos prides on finding simple solutions, through the sound use of materials and production methods, in a process that starts from within the object.

LAURINDO MARTA

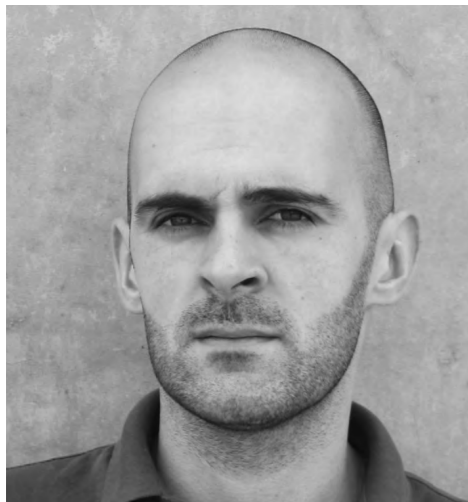

With an academic degree in Fine Arts - Sculpture by the Escola Superior de Artes e Design at Caldas da Rainha since 2009, the practice that has occupied him ever since, exhibiting his work individually as well as collectively.

Recently, he has also been dedicated to the design project - DENTE DE CÃO - trying to create objects, predominantly in the furniture area, characterized by their versatility allowing to change them into multiple configurations, easily adapted to the needs of each user.

The differentiating element of each piece is searched on the technologies and ingeniousness combined with design, giving them originality and uniqueness.

LEONHARD PFEIFER



Born in New Zealand, Leonhard Pfeifer studied Industrial Design in Australia and worked across a wide range of industries before establishing his design studio in East London. Since 2003 he has worked developing collections of furniture and stand-alone pieces for design-led retail and contract markets across Europe and internationally.

Working across a range of design industries including consultancy, r&d and manufacturing, Pfeifer and his team have a wide scope of experience and a pragmatic approach to furniture design. the studio works globally with brands, retail partners, and producers.

PIERRE DUBOURG



With a master degree in product design, in 2018 Pierre Dubourg joined the Arik Levy design studio and became a project manager (furniture + industrial design).

Since the opening of his studio in 2013, he collaborates with artisans and brands as Hartô, Édition Versant, Airbus, Monolithe Edition, Dasras, etc.

At the same time, he is the art director of Monolithe Edition and he's teaching product design.

RAFAEL OLIVA



Rafael had his first contact with woodworking in childhood, influenced by his grandfather, an Italian carpenter from Atripalda, a small town near Avellino in Campania.

He graduated in Product Design from FAAP, with a period at the University of Plymouth, and gained experience at notable companies and studios, including Philips and Estúdio Campana.

At Instituto Campana, he worked teaching craft practices to young people from the Moinho community in São Paulo.

In 2019, he founded LABMOBILI, marking the beginning of his own independent practice.

RAMOS BASSOLS



Ramos Bassols are David Ramos and Jordi Bassols, both industrial designers. The studio started in 2004, after several years of experience in different fields such as urban furniture, tableware, lighting and office furniture.

Based in Barcelona, Ramos Bassols offers a personal view on contemporary design, always searching for the balance between form, function and aesthetics. Products with clean lines, yet warm and attractive for the public.

The studio has been granted several award.

STUDIO GUD



Studio Gud is a project of the designers Paulo Neves and Alexandre Kumagai, based in Porto, Portugal.

The project was born of a long-standing friendship between them. After accumulating a large experience, Alexandre as senior designer at De La Espada and Paulo as senior designer at ALSC, both decided it was time to carry out this experience on a personal project, offering interior and product design services.

SURICATA DESIGN STUDIO



Suricata Design Studio are a collective located in Porto's downtown.

Going through a normal process of growth, evolution, acknowledgment and continuing professional development, maturity and professional experience have been obtained due to a direct engagement with national and international scope projects, with a special emphasis on areas such as automotive design, aeronautics, equipment and the ITC.

They develop their work within the industrial design range, having a set of connections with formal and informal partners, which allows providing adequate responses to requests of any creative sphere.

ÜMIT ÇAĞLAR



Ümit Çağlar is an interior architect and designer specialised in interior architecture, furniture design, yacht design and media & digital arts. Thanks to his multidisciplinary training he likes to space across design fields and artistic approaches.

He holds a BDes and a MSc from Izmir University of Economics, and MA from Berliner Technische Kunsthochschule. He was raised by a carpenter family, and he is now following their footsteps. Thanks to the creative atmosphere he grew up in, he worked towards defining his own design language. Ümit's approach seeks to combine organic lines with natural shapes and materials.

VARIAFORMA

Variaforma is a multidisciplinary design studio based in Milan area. It was born as the set of several professional identities that do not mix, but overlap; thus, giving life to the "various forms" of a project.

The sum of various professional skills generates alchemy, useful for analysing and dealing with the project from every point of view, with the aim of offering a multifaceted service, creating projects marked by a strong aesthetic/communicative component.

The studio was founded in 2014 by David Dolcini, Pietro Manfredi and Mauro Corinti.



MATERIALS & COLORS

The choice of the materials, fabrics and colors is what gives each piece its expression and plays an important role in the interior design project.

Along with our collection, we have our own selection of materials like wood and marble as well as a selection of different types of leather and fabrics.

You can select from a large variety of colors, materials and finishes to tailor our pieces and adapt it to the look and feel of different spaces.

Due to typographical and computer screens variations, we cannot guarantee that colors shown here are truly representative of our products.

Prior to purchasing, please contact us. We recommend that you order a single sample of any material or purchase a box with all the materials.

WOOD



WOOD

OAK | NATURA



OAK | WHITE OIL

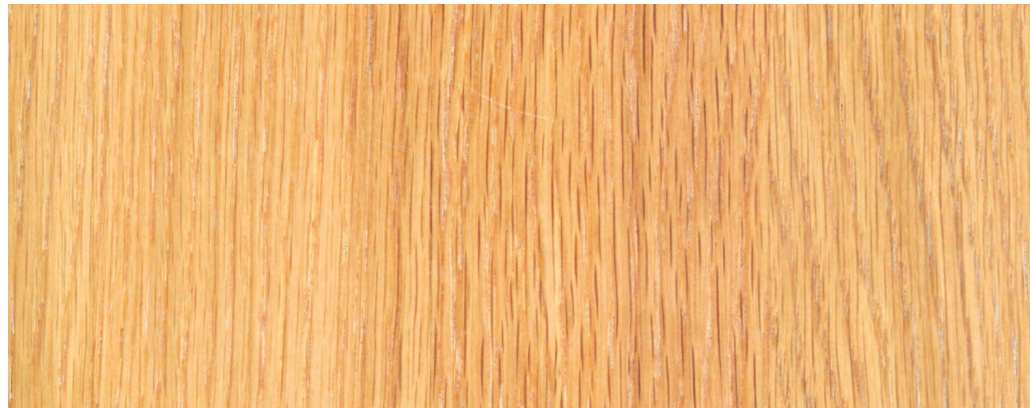

OAK | SMOKED OPEN PORE

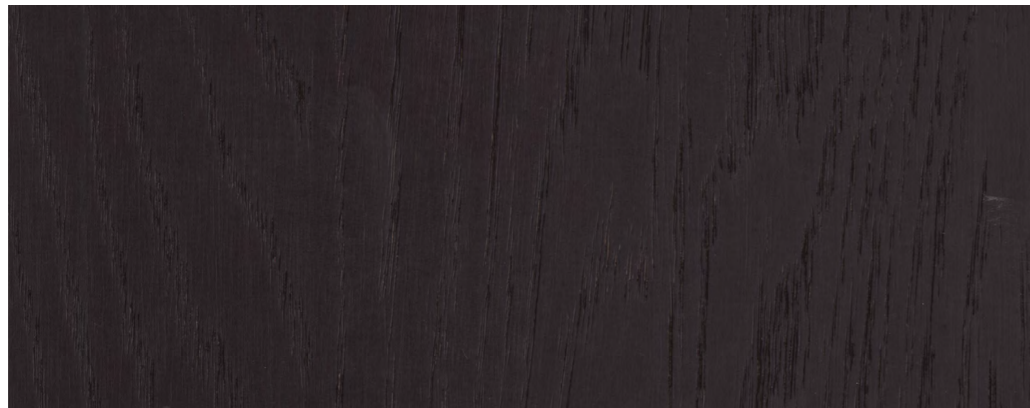

WOOD

OAK | GOLDEN BROWN



WALNUT | NATURA

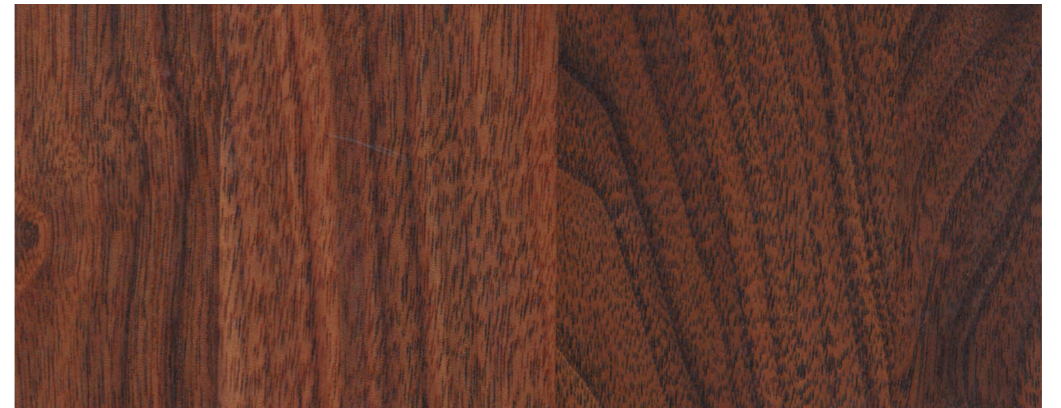

WALNUT | UV PROTECT

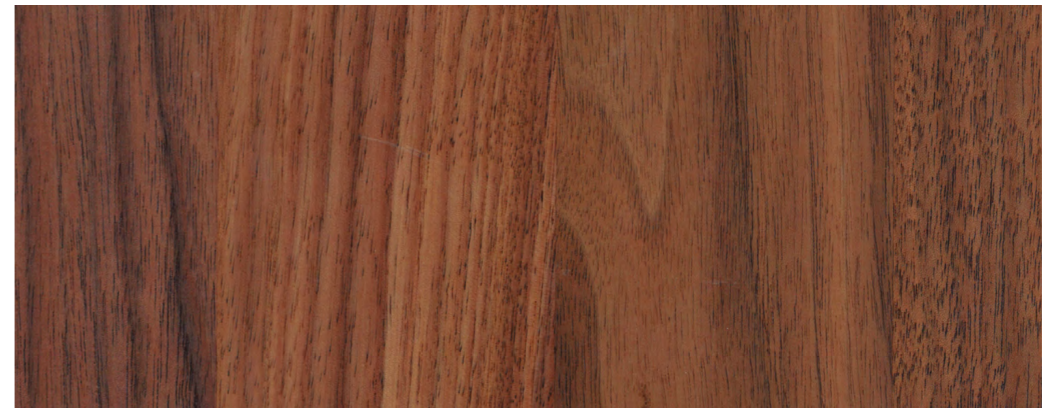

MARBLE | STONE



MARBLE | STONE

STANDARD MARBLE



ESTREMOZ

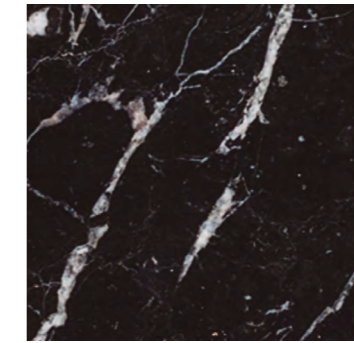

NERO MARQUINA

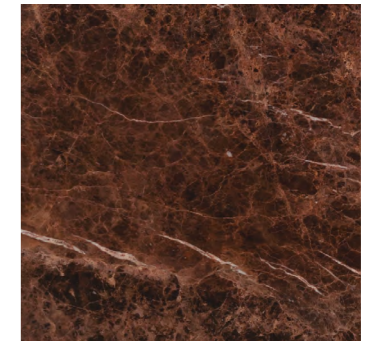

EMPERADOR

PREMIUM MARBLE



CALACATTA

STONE



TRAVERTINE
*ONLY AVAILABLE FOR LILY TABLES

FABRICS

GROUP A



FABRICS | GROUP A

CAMPO

Composition 90% PL | 10% PC

Width 140cm | 55,12"

Martindale 145 000

Flame Resistance BS5852-0 (UK)

More Features Water repellent



TAALCAMPO02

TAALCAMPO03

TAALCAMPO05

TAALCAMPO09

TAALCAMPO13



TAALCAMPO14

TAALCAMPO15



MORE COLOURS

CHALET

Composition 100% PL

Width 140cm | 55,12"

Martindale 50 000

Flame Resistance BS5852-0 (UK)

More Features Water repellent

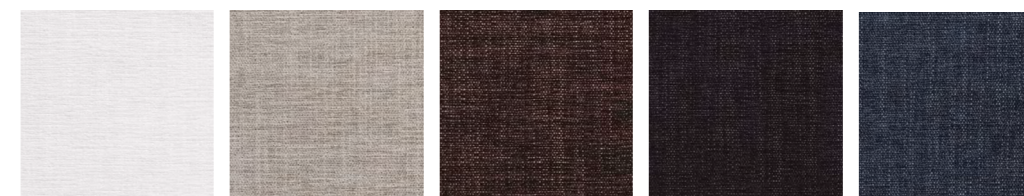

TAALCHALET01

TAALCHALET02

TAALCHALET03

TAALCHALET13

TAALCHALET16

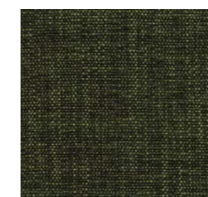

TAALCHALET18

TAALCHALET19



MORE COLOURS

AMADEUS

Composition 22% PC | 22% WV | 22% PL | 14% VI | 13% CO | 7% LI
Width 140cm | 55,12"
Martindale 30 000
Flame Resistance BS5852-0 (UK) | EN1021-1 (EU) | NFPA260 (USA)
More features Natural fibers



TAEAMADEUS0025 TAEAMADEUS0225 TAEAMADEUS0520 TAEAMADEUS0762 TAEAMADEUS0855



TAEAMADEUS1534 MORE COLOURS

MADISON

Composition 63% CO | 37% LI
Width 140cm | 55,12"
Martindale 32 500
Flame Resistance BS5852-0 (with FR foam) (UK)
More Features Natural fibers



TADTMADISON12035 TADTMADISON12053 TADTMADISON12132 TADTMADISON12143 TADTMADISON12151



TADTMADISON24196 TADTMADISON24197 TADTMADISON24251 MORE COLOURS

ALMO

Composition 78% PL | 10% PC | 7% LI | 5% WO
Width 140cm | 55,12"
Martindale 100 000
Flame Resistance BS5852-0 (UK)

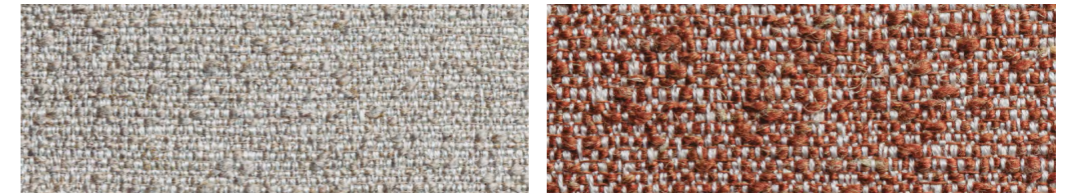

TAALALMO03

TAALALMO05

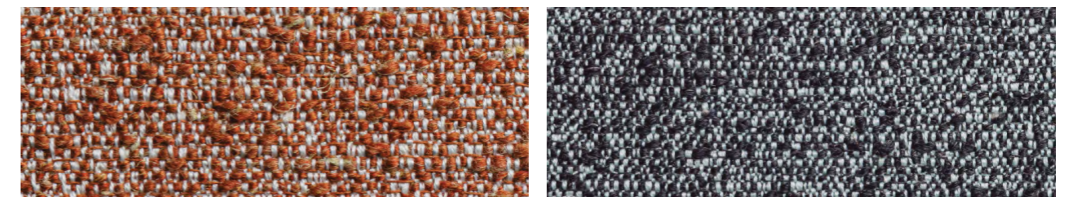

TAALALMO06

TAALALMO09



MORE COLOURS

FABRICS | GROUP A

WAIKIKI

Composition 100% PL

Width 140cm | 55,12"

Martindale 35 000

Flame Resistance N/A

More Features Water and oil repellency | Antibacterial



TAAFWAIKIKIBLANCO



TAAFWAIKIKIARENA

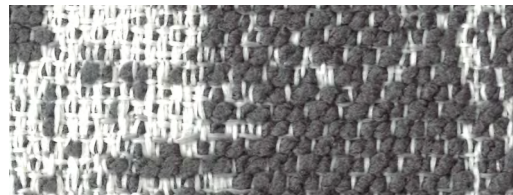

TAAFWAIKIKIALUMINIO

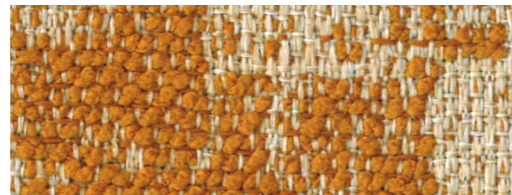

TAAFWAIKIKIMOSTAZA

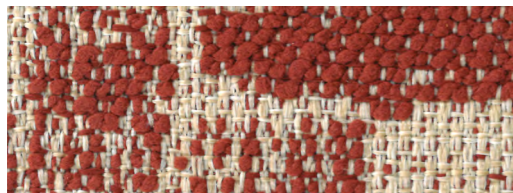

TAAFWAIKIKITEJA



TAAFWAIKIKIMARINO

FABRICS

GROUP B



LOOP LOOP

Composition 28% PL | 25% PC | 24% WO | 23% rCO
Width 140cm | 55,12"
Martindale 52 000
Flame Resistance BS5852-0 (UK) | TB 117-2013 (USA)
More Features Natural fibers

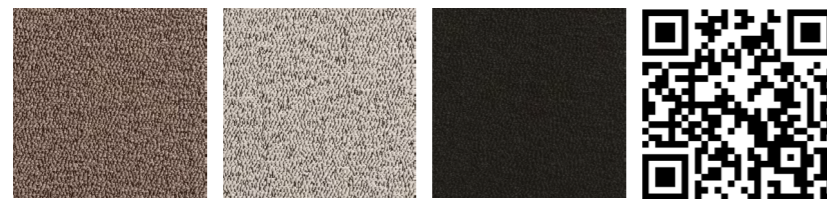

TBDDLOOPLOOP002 TBDDLOOPLOOP005 TBDDLOOPLOOP008 MORE COLOURS

MOLERA

Composition 44% CO | 30% PES | 17% LI | 5% BAMB | 4% PA
Width 136cm | 53,54"
Martindale 40 000
Flame Resistance N/A



TBDMOLERA001 TBDMOLERA002 TBDMOLERA005 TBDMOLERA007 MORE COLOURS

KYRI

Composition 63% VI | 27% LI | 7% PL | 3% PA
Width 140cm | 55,12"
Martindale 40 000
Flame Resistance BS5852-0 (UK) | CAL 117 (USA) | EN1021-1 (EU) | NFPA260 (USA) | TB 117-2013 (USA)
More Features Reach compliant | PFAS free



TBROKYRI09 TBROKYRI12 TBROKYRI21 TBROKYRI39 MORE COLOURS

LORTON

Composition 100% rPET
Width 144cm | 56,69"
Martindale 48 000
Flame Resistance BS5852-0 (UK)

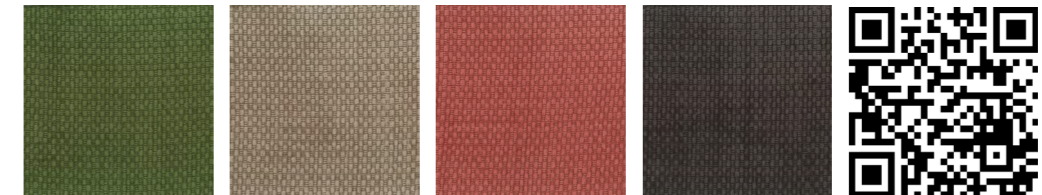

TBOLLORTON01 TBOLLORTON04 TBOLLORTON05 TBOLLORTON12 MORE COLOURS

TÁLIO

Composition 42% CO | 38% VI | 15% PL | 5% LI
Width 140cm | 55,12"
Martindale 25 000
Flame Resistance N/A



TBPOTALIO01 TBPOTALIO02 TBPOTALIO03 TBPOTALIO04 TBPOTALIO05

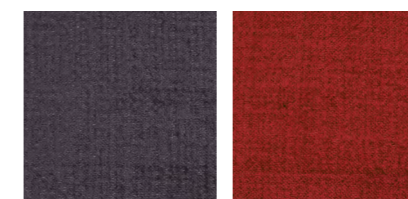

TBPOTALIO06 TBPOTALIO07

FABRICS | GROUP B

SIÈGE

Composition 100% CO

Width 140cm | 55,12"

Martindale 10 000

Flame Resistance N/A (FR TREATMENT AVAILABLE, SUBJECT TO INQUIRY)

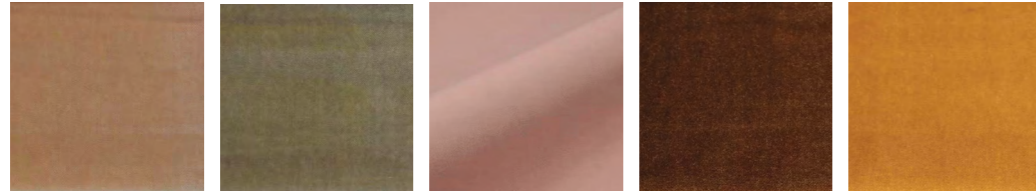

TBALSIEGE0043

TBALSIEGE0893

TBALSIEGE1601

TBALSIEGE0452

TBALSIEGE0166

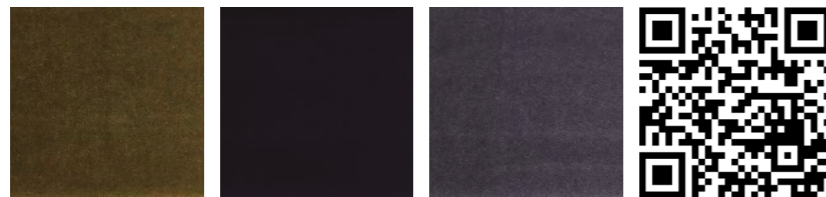

TBALSIEGE7033

TBALSIEGE0668

TBALSIEGE0881

MORE COLOURS

FABRICS

GROUP C



SYCOMORE

Composition 32% AC | 19% CO | 17% VI | 8% LI | 7% ALP | 7% VW | 6% PL | 3% PO | 1% EL
Width 140cm | 55,12"
Martindale 30 000
Flame Resistance BS5852-0 (UK) | EN1021-1 (EU) | NFPA260 (USA) | TB 117-2013 (USA)

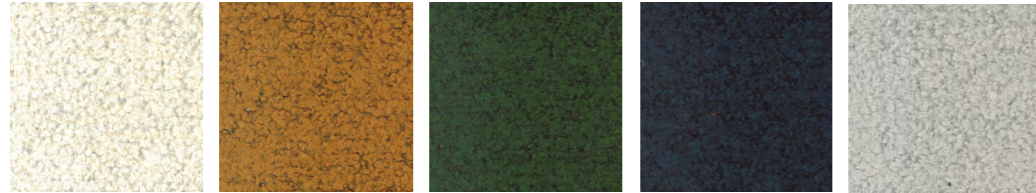

TCPFSYCOMORE001 TCPFSYCOMORE002 TCPFSYCOMORE003 TCPFSYCOMORE004 TCPFSYCOMORE005



TCPFSYCOMORE006

EMBER

Composition 60% PL | 40% PC
Width 140cm | 55,12"
Martindale 100 000
Flame Resistance CAL 117 (USA) | EN1021-1 (EU) | NFPA260 (USA)

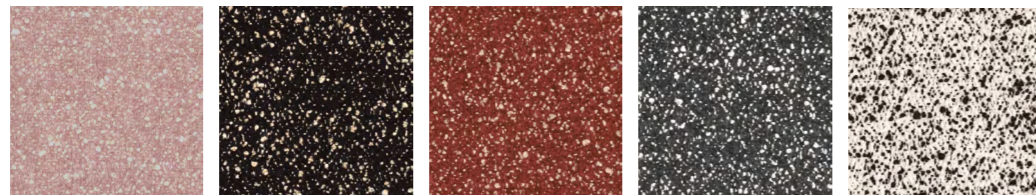

TCKDEMBER01 TCKDEMBER02 TCKDEMBER03 TCKDEMBER04 TCKDEMBER05



TCKDEMBER07



MORE COLOURS

SAPPHEO

Composition 46% VI | 21% WO | 21% PC | 12% PA
Width 142cm | 55,91"
Martindale 25 000
Flame Resistance CAL 117 (USA) | EN1021-1 (EU) | NFPA260 (USA)
More Features Special finish: anti-shrink, anti-pilling dimout option on request



TCZCSAPPHEO001

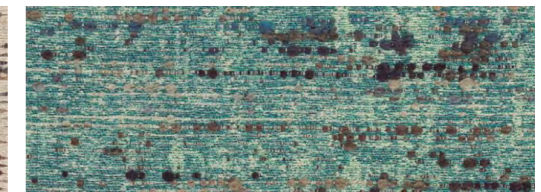

TCZCSAPPHEO002

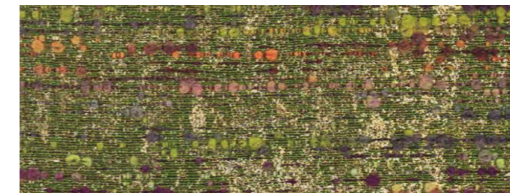

TCZCSAPPHEO003



MORE COLOURS

KUBA

Composition 60% VI | 40% CO
Width 138 cm | 54,33"
Martindale 50 000
Flame Resistance FFFSR 1988 (UK)



TCLSKUBA01

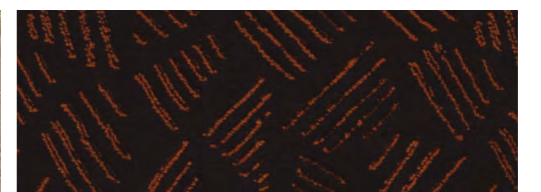

TCLSKUBA03

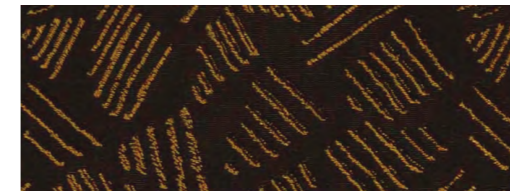

TCLSKUBA04



TCLSKUBA05



MORE COLOURS

LEATHER



LEATHER

TEXTURE

Composition 100% LH

Width 5,0m²

Martindale 50 000

Pilling N/A

Flame Resistance BS5852-0 (UK) | EN1021-1 (EU)

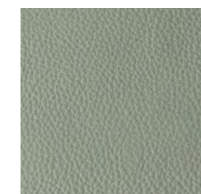

LELTEXTURE6203

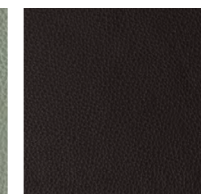

LELTEXTURE6207



LELTEXTURE6212



LELTEXTURE6213



LELTEXTURE6228

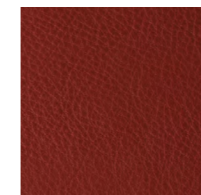

LELTEXTURE6241



LELTEXTURE6252



LELTEXTURE6258

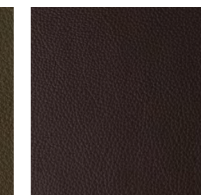

LELTEXTURE6293



MORE COLOURS

LEATHER

PLAIN

Composition 100% LH

Width 5,0m²

Martindale 50 000

Pilling N/A

Flame Resistance BS5852-0 (UK) | EN1021-1 (EU)

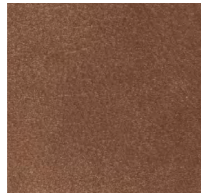

LELPLAIN24003

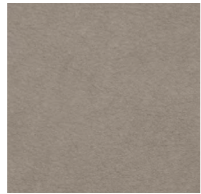

LELPLAIN24009



LELPLAIN24017



LELPLAIN24018



LELPLAIN24021



LELPLAIN24024



LELPLAIN24025



LELPLAIN24027



LELPLAIN24029



MORE COLOURS



CARE
&
MAINTENANCE

CARE & MAINTENANCE

Although our products are built to last a lifetime, they need some maintenance care to keep them in perfect condition.

During the production, we do all the necessary care to stabilize the wood, however as it is a natural material some changes may occur with time. Solid wood reacts sensitively to environmental changes, such as temperature, humidity and UV rays (sunlight). It is very important to gradually introduce the furniture to any new environment.

Variations in temperature and humidity may cause different reactions in solid wood furniture. If conditions are dry, the timber may shrink, causing cracks or warping. On the other hand, in surroundings with high humidity, the wood may expand. In both cases, the wood will slowly return to its original state as soon as the conditions are back to normal around 40% - 60% of relative humidity.

UV light may change the colour of the wood. Lighter woods (oak) tend to get darker whereas darker woods (walnut) might change the colour to a lighter tone.

We pay great attention to our wood selection, however solid wood is a natural material and colour variations within one piece of furniture are possible.

Our wood is hand-picked and hand-assembled. Boards with larger knots than 20mm in diameter are not being used.

Apart from the attention to the environmental conditions, taking care of your solid wood furniture couldn't be easier.

Since March 2022 we are using a hardwax oil as a finishing for all our wooden surfaces to protect the natural beauty of the material.

For daily maintenance just use a dry cloth, and from time to time clean all the surfaces with a slightly damp cloth. We recommend to wipe up liquid spills immediately with a dry cloth to avoid longterm damages on the surface.

Small damages and scratches can be removed with a fine sanding paper (grit 220). Please sand always in the direction of the grain. Raw, exposed oak wood reacts with metal and leaves black marks. Therefore please avoid using steel wool to smooth your surface. After removing the scratches, apply again the hardwax oil on the previously treated spot. Use a soft cotton cloth for this procedure.

WARNING: used oil cloths may self-ignite if not properly stored. Destroy oil cloths and sponges by rinsing in cold water or keep in airtight metal or glass containers.

WOOD

PREVENT CRACKING AND WARPING

WINTER

In winter, solid wood furniture is particularly susceptible to shrinkage as the cold, dry air from outside seeps into the home, driving down the relative humidity often to as low as 20% or lower. This shrinkage may cause cracks, and such cracks usually appear within a plank on planar elements such as tabletops or cabinet tops, near the end of the plank. Cracks can happen very quickly, within hours. These cracks will not affect the performance of the product, and can be embraced as a natural characteristic of the material. With increased humidity, the plank may swell, decreasing the appearance of any cracks.

These instructions include guidance for maintaining the correct humidity levels for your solid wood furniture to control movement, and options for responding to any wood movement that does occur.

DAY TO DAY - LIVING WITH SOLID WOOD FURNITURE

Keep an eye on the relative humidity in the product's environment throughout the product's life, and alter the environment as needed to achieve 50% relative humidity.

MEASURE AND ADJUST HUMIDITY

The simplest way to measure the humidity in the environment is by using an RH Hygrometer. If the humidity in the environment falls below 45%, keep a humidifier next to the piece of furniture to increase the moisture in its environment.

Alternatively, if a humidifier is not available, place a bucket filled with water near the piece of furniture, as this will add humidity to the room as the water evaporates.

REAPPLY WAX REFRESHER OR OIL - OILED FINISHES ONLY

If your furniture has an oil finish, keep plenty of Wax Refresher or oil on hand. The frequent application of wax or oil will keep the wood as sealed as possible, providing a protective barrier against the environment.

PROTECT FROM DIRECT HEAT AND COLD

Please ensure that direct contact with hot objects is avoided by using tablemats. Do not place your solid wood furniture next to direct sources of heat or cold such as radiators or air conditioning ducts.

PROTECT FROM BRIGHT LIGHT/DIRECT SUNLIGHT

Timber is a natural material and the colour/tone can bleach, fade and shrink, causing cracks if the table is exposed to UV light, and this process is accelerated the more intense the exposure. You may wish to limit exposure to sunlight such as by closing curtains when the room is not in use. Additionally you may wish to consider installing ultra-violet (UV) filtering film on windows to limit the fading and discolouration caused by UV rays.

SPILLAGES

Any spillages should be wiped clean immediately. Once the immediate spillage is cleared, ensure that the whole surface is wiped clean with a damp cloth. Do not use any corrosive products such as bleach anywhere near the timber.

WINTER CARE INSTRUCTIONS

PROBLEM SOLVING

If cracks appear in your furniture, please do not be alarmed. This is a natural response of the timber to the changing environment.

CONTROL RELATIVE HUMIDITY

The product's environment should ideally have a relative humidity of 50%. Measure the humidity in the environment by using an RH Hygrometer. If the humidity in the environment is lower than 45%, keep a humidifier next to the piece of furniture to increase the moisture in its environment to 50%. Alternatively, if a humidifier is not available, place a bucket filled with water near the piece of furniture, as this will add humidity to the room as the water evaporates.

LIMIT SUN EXPOSURE

If relevant, move the furniture away from direct sunlight, cover it with a tablecloth, install blinds, or use UV filters on glass.

RESTORE MOISTURE WITH A WET CLOTH - OILED FINISHES ONLY

Wipe all exposed areas of the timber with a wet cloth twice daily for two weeks. The cloth should be slightly wetter than damp, so when you wipe it across the surface you can see a glaze of water across the timber, but no puddles. Wipe all exposed surfaces with special concentration on edges (end grain) as this is where most of the moisture escapes. This wet cloth procedure will affect the surface finish, raising the grain, so at the end of the two weeks, we recommend that you restore the beauty of the finish by sanding down the item to a smooth finish, then applying Wax Refresher.

FILL CRACKS WITH SOFT WAX

If cracks remain after following all of the above advice, you may wish to fill them with a cosmetic repair wax in a matching colour. The wax will temporarily fill the crack, then when conditions are more humid and the timber naturally swells to regain its original shape, the wax will push out as the crack closes and can be removed easily.

Alternatively, a professional can carry out a repair that involves applying wood glue and sawdust to the crack.

MARBLE

Marble is a natural stone, thus each cut has individual colour and pattern variations. Marble is tolerant of direct heat, but it is softer and more porous than some stones and thus requires delicate care. Our marble is honed to a beautiful matte finish, then coated with a sealant to protect it from spillages, though any spills should be wiped clean immediately.

For daily maintenance, use a soft dry microfibre cloth to remove dust. For wet cleaning, use a damp cloth and a pH-neutral cleaner designed for stone. Never use standard household cleaners or abrasives. Do not let vinegar or acidic foods come in direct contact with the marble as this will damage the surface.

Periodically seal the marble with a suitable marble sealant. This should be done in response to the level of wear, approximately once every few years. The best way to determine when to reseal is by splashing water on the surface - if it fails to bead up, then it is time to reseal. Sealing will protect against stains and damage, but please note that some sealants can change the appearance of your marble. The best protection against scratches is prevention. Always use coasters and mats to protect the marble from objects that may scratch the surface.

GLASS

Our clear glass is tempered for great strength. The best protection against scratches is prevention. Always use coasters and mats to protect the glass from objects that may scratch the surface. Regularly dust with a feather duster to remove dirt and other small particles which can scratch the glass. To clean, first dust thoroughly, then a mild glass cleaner may be used.

FABRICS

Regular cleaning is important in order to keep the upholstery textile looking its best and to prolong its life. Dust and dirt wear down the textile and also reduce its fire-retardant properties.

Vacuum frequently, ideally every week, at half power where appropriate. Wipe upholstery fabrics made from polyurethane with a dry or moist cloth. May also be vacuum cleaned with a soft brush.

LEATHER

Leather is hardwearing and beautiful. All of our leathers benefit from regular vacuuming to remove dust. Keep sharp and heavy objects such as keys away from the leather to avoid marking. Avoid excessive heat and if possible direct sunlight as these will dry the leather. High humidity, warm temperatures, poor ventilation, and soiling can cause mould to grow on leather. It is important to keep the leather clean and to control the environment where the leather products are kept to prevent mould formation. We recommend using a Hygrometer to monitor the Relative Humidity in your home, to ensure that the conditions are neither too humid, nor too dry. The ideal relative humidity is 50%.

Air conditioners or dehumidifiers can remove moisture from the air, and either should be used with windows and doors kept closed.

If mould does form, follow this procedure: Remove mould with a soft bristle brush (such as toothbrush), if possible outdoors to prevent scattering mildew spores in the home. Run a vacuum cleaner attachment over the surface of the leather to draw out more of the mould, being sure to immediately dispose of the vacuum bag outdoors.

Dry the leather with an electric heater, fan, or sun and air. If necessary, sponge lightly with thick suds of mild soap and wipe with a clean damp cloth, being sure to avoid soaking the leather.

Below are three types of leather offered by Wewood. If in doubt as to which leather applies to you, please contact us.

BRASS

Brass must be routinely maintained to retain the desired appearance. The darkening or black spotting on the brass surface is simply oxidation taking place. If left untreated, brass will eventually turn entirely dark. The dark oxidized state is the natural color of all copper alloys.

We recommend that you use regularly polish the brass surfaces in order to stop the brass from tarnishing or turning dark. Brass metal polish helps keep the metals shiny as well as cleaning off the tarnish. Before applying the brass polish, you should wash the object in warm, soapy water, then rinse and let it dry well. Polish the brass surface with a soft sponge or cloth according to the specific instructions on the brass polish bottle. Remember to wash away all polish and let it dry.

Rub or wash away all the brass polish. If there is polish left on the object, it can cause the object to tarnish again quicker.

MORE INFORMATION

For more information please contact: quality@wewood.eu

EXCLUSIVE DESIGN

Our products are made under exclusive license agreements with the designer.

We like to make products that challenge us and our primary focus is always on improving the quality of our existing collection and ensuring maximum longevity and sustainability. Occasionally, we introduce new products.

NOBLE MATERIALS

Most of our furniture is crafted from solid wood, a natural material appreciated for its inherent beauty and ability to age with grace over time. It is a vital part of the world's eco system, and it's our duty to work it responsibly.

The wood that we use in our products, both oak and walnut, comes from responsibly managed forests and other controlled sources.

The FSC Forest Management Certification confirms that a forest is being managed in an environmentally responsible manner preserving biodiversity and benefiting the lives of local people and workers.

Please note that some items in this catalogue may have been discontinued or taken out of production. Prices, colors and/or composition of our products, may change over time. We recommend a visit to our website for an up-to-date version of our collection.

CONCEPT
WEWOOD - PORTUGUESE JOINERY

CREATIVE DIRECTION
JOANA MARCELINO

PRINTING
UNIARTE

DAILY INSPIRATION

INSTAGRAM, FACEBOOK & PINTEREST
@WEWOODPORTUGUESEJOINERY

LISBON STORE

RUA ROSA ARAÚJO N.º 31
1250-194 LISBOA | PORTUGAL

T. +351 932 492 434
INFO@WEWOOD.EU

HEADQUARTERS

RUA D. AFONSO HENRIQUES, 77
4585 - 322 GANDRA | PORTUGAL

GPS N41°10'21.44" W8°26'20.07"

T. +351 224 114 050
M. +351 932 492 434

WWW.WEWOOD.EU
INFO@WEWOOD.EU

